

CONTENTS

SAFETY GUIDELINES	3
I. SAFETY	4
II. YOUR SCOOTER	8
III. BATTERIES AND CHARGING	17
IV. OPERATION	24
V. COMFORT ADJUSTMENTS	26
VI. DISASSEMBLY AND ASSEMBLY	32
VII. BASIC TROUBLESHOOTING	34
VIII. CARE AND MAINTENANCE	36

SAFETY GUIDELINES



WARNING! An authorized Provider or qualified technician must perform the initial setup of this scooter and must perform all of the procedures in this manual.

The symbols below are used throughout this owner's manual and on the scooter to identify warnings and important information. It is very important for you to read them and understand them completely.



WARNING! Indicates a potentially hazardous condition/situation. Failure to follow designated procedures can cause either personal injury, component damage, or malfunction. On the product, this icon is represented as a black symbol on a yellow triangle with a black border.



MANDATORY! These actions should be performed as specified. Failure to perform mandatory actions can cause personal injury and/or equipment damage. On the product, this icon is represented as a white symbol on a blue dot with a white border.



PROHIBITED! These actions are prohibited. These actions should not be performed at any time or in any circumstances. Performing a prohibited action can cause personal injury and/or equipment damage. On the product, this icon is represented as a black symbol with a red circle and red slash.

I. SAFETY

PRODUCT SAFETY SYMBOLS

The symbols below are used on the scooter to identify warnings, mandatory actions, and prohibited actions. It is very important for you to read and understand them completely.

NOTE: *There are more warnings identified and explained in the Consumer Safety Guide that is included with your scooter. Please become familiar with all the warnings and safety information found in the Consumer Safety Guide and refer to this resource often.*



Read and follow the information in the owner's manual.



Indicates UNOCCUPIED scooter securement points.



Scooter information label



Manufactured in



or



Does not meet ISO 7176-19 standards for occupied transport in a motor vehicle. When traveling in a motor vehicle, do not sit in your Scooter.

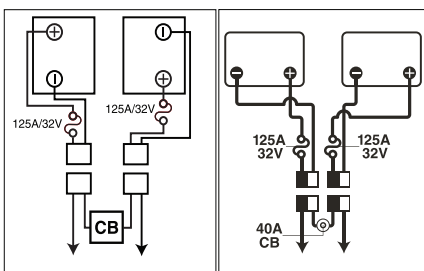

Battery Set Configuration:

+ = Positive (Red) Terminal Post

- = Negative (Black) Terminal Post

Connect Red wires to Red Positive (+) Terminal Posts.

Connect Black wire to Black Negative (-) Terminal Posts.



Fully charge batteries before operating.

Remove key from an unattended Scooter.

I. SAFETY

GENERAL



MANDATORY! Do not operate your new scooter for the first time without completely reading and understanding this owner's manual and the Consumer Safety Guide.

Your scooter is a state-of-the-art life-enhancement device designed to increase mobility. We provide an extensive variety of products to best fit the individual needs of the scooter user. Please be aware that the final selection and purchasing decision regarding the type of scooter to be used is the responsibility of the scooter user, who is capable of making such a decision and his/her healthcare professional (i.e., medical doctor, physical therapist, etc.).

The contents of this manual are based on the expectation that a mobility device expert has properly fitted the scooter to the user and has assisted the prescribing healthcare professional and/or the authorized Provider in the instruction process for the use of the product.

There are certain situations, including some medical conditions, where the scooter user will need to practice operating the scooter in the presence of a trained attendant. A trained attendant can be defined as a family member or care professional specially trained in assisting a scooter user in various daily living activities.

As you begin using your scooter during daily activities, you will probably encounter situations in which you will need some practice. Simply take your time and you will soon be in full and confident control as you maneuver through doorways, on and off elevators, up and down ramps, and over moderate terrain.

Additional general information can be found on the supplemental information sheets and booklets included in your Owner's Package. Please fully read and review the information, and keep it readily available for future reference.

Here are some precautions, tips, and other safety considerations that will help you become accustomed to operating the scooter safely.

I. SAFETY

PRE-RIDE SAFETY CHECK

Get to know the feel of your scooter and its capabilities. We recommend that you perform a safety check before each use to make sure your scooter operates smoothly and safely.

Perform the following inspections prior to using your scooter:

- Check the condition of the tires. Make sure they are properly inflated and not damaged or excessively worn.
- Check all electrical connections. Make sure they are tight and not corroded.
- Check all harness connections. Make sure they are secured properly.
- Check the brakes to ensure they operate properly.
- Check the battery condition meter to ensure the batteries are fully charged.
- Ensure the manual freewheel lever is in drive mode before sitting on the scooter.

If you discover a problem, contact your authorized Provider for assistance. Please refer to the Contact Information insert in your Owner's Package.

BRAKING INFORMATION

Your scooter is equipped with these powerful brake systems:

- Regenerative: Uses electricity to rapidly slow the vehicle when the throttle control lever returns to the center/stop position.
- Disc Park Brake: Activates mechanically after regenerative braking slows the vehicle to near stop or when power is removed from the system for any reason.
- (Optional) Handbrake: This lever provides you with emergency stopping power. See II. "Your Scooter."

HANDBRAKE LEVER (OPTIONAL)

The handbrake lever contains hydraulic fluid. When the lever is depressed, the fluid is pushed through the brake line to engage the brake pads against the brake discs. The handbrake lever is a completely sealed unit, meaning that the hydraulic fluid should not leak; however, there are certain safety measures that should be taken if the handbrake lever becomes cracked or damaged.

- Do not touch spilled material unless wearing protective equipment, such as safety goggles and gloves.
- For small spills, cover the material with dry earth, sand or other non-combustible absorbent material. Once absorbed, enclose the material in a plastic bag and contact your local waste disposal agency for proper disposal measures. Do not expose the material to waterways or sewers.
- If the eyes are exposed, check for and remove contact lenses. Flush eyes with cool, clean, low-pressure water while occasionally lifting and lowering the eyelids. Seek medical attention if excessive tearing, redness or pain persists.
- If the skin is exposed, remove all contaminated clothing. Wipe off excess material and wash exposed skin with soap and water. Seek medical attention if skin appears damaged or if irritation persists. Thoroughly clean contaminated clothing before reuse. Discard contaminated leather goods.
- If ingested, do not induce vomiting or give anything to drink unless directed to by a physician. Never give anything by mouth to a person who is not fully conscious. Seek medical attention immediately.

I. SAFETY

- If inhaled, move the affected individual to fresh air. If the affected individual is not breathing, immediately begin rescue breathing. If breathing is difficult, 100% humidified oxygen should be administered by a qualified individual. Seek medical attention immediately and keep the affected individual warm and at rest.
- If ignited, use dry chemical, foam, carbon dioxide or water fog to extinguish.

WARNING! Do not modify the handbrake lever or attempt to replace the hydraulic fluid. If damage occurs, follow the safety information in this section and contact your authorized Provider for handbrake replacement. The hydraulic handbrake should only be serviced or replaced by your authorized Provider.



WARNING! The handbrake contains hydraulic fluid that can cause mild skin, eye and nasal/bronchial irritation. Do not attempt to adjust or service the handbrake without proper protective equipment such as safety goggles and gloves and wash hands after handling.

II. YOUR SCOOTER

TILLER CONSOLE

The tiller console houses all of the controls needed to drive your scooter, including the speed adjustment dial, key switch, battery condition meter, horn buttons, turn signal buttons and the throttle control lever. Please note that some of the features listed in this section are optional items and may not appear on your scooter. Please refer to the Scooter Features Table on the inside of the front cover of this owner's manual to determine which console figure to choose. Contact your authorized Provider for more information. See figure 1, 2, 3, or 4.



PROHIBITED! Do not expose the tiller console to moisture. In the event that the tiller console does become exposed to moisture, do not attempt to operate your scooter until the tiller console has dried thoroughly.

IDENTIFICATION KEY FOR FIGURES 1, 2, 3 AND 4

- | | |
|------------------------------|------------------------------|
| 1. HORN BUTTON | 9. BATTERY CONDITION METER |
| 2. *LEFT TURN SIGNAL BUTTON | 10. KEY SWITCH |
| 3. *HAZARD LIGHTS SWITCH | 11. *MIRROR AND MIRROR PLUGS |
| 4. LIGHT SWITCH | 12. *HANDBRAKE LEVER |
| 5. *RIGHT TURN SIGNAL BUTTON | 13. *PUDDLE LIGHT SWITCH |
| 6. *HI-LOW SWITCH | 14. *POWER SEAT SWITCH |
| 7. THROTTLE CONTROL LEVER | 15. *PUDDLE LIGHT |
| 8. SPEED ADJUSTMENT DIAL | |

*OPTIONAL COMPONENTS AVAILABLE ON SOME MODELS

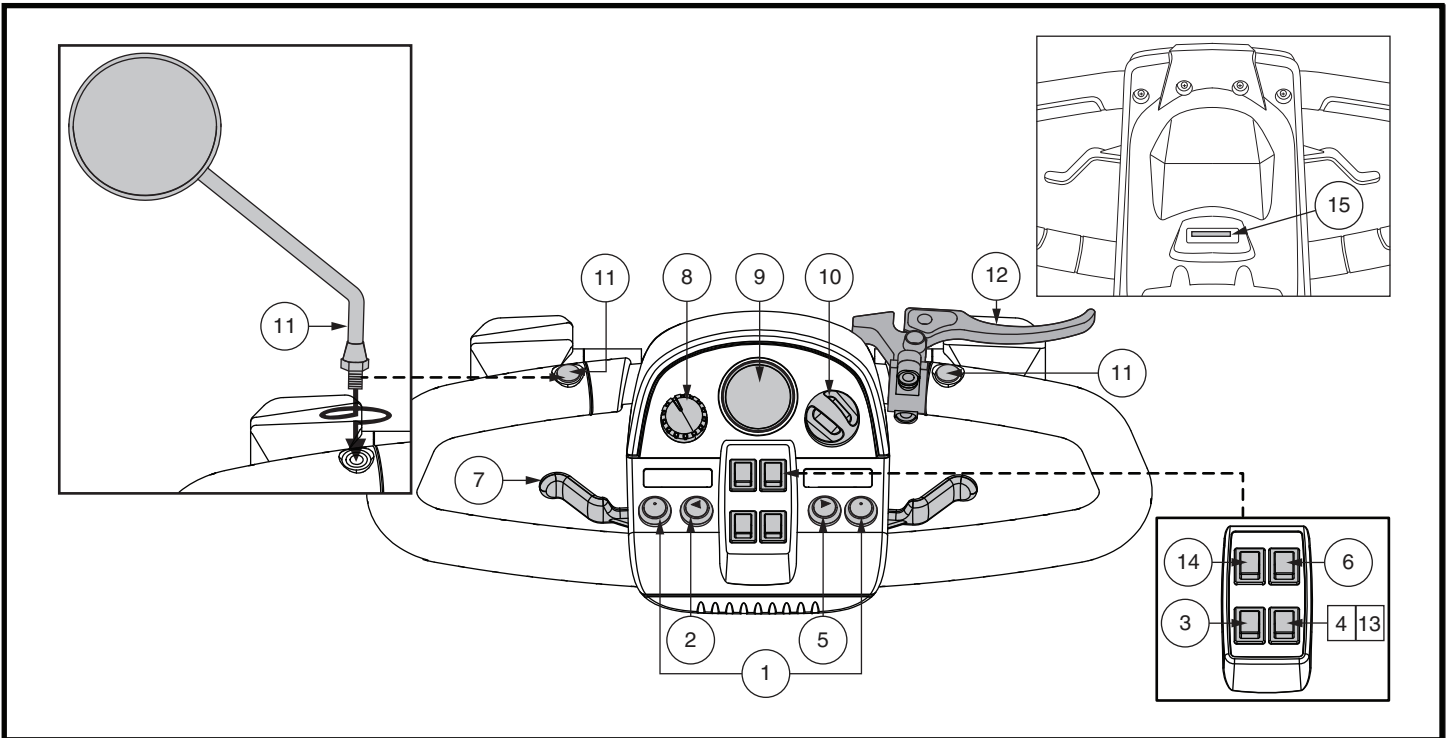

Figure 1. Tiller Console A

II. YOUR SCOOTER

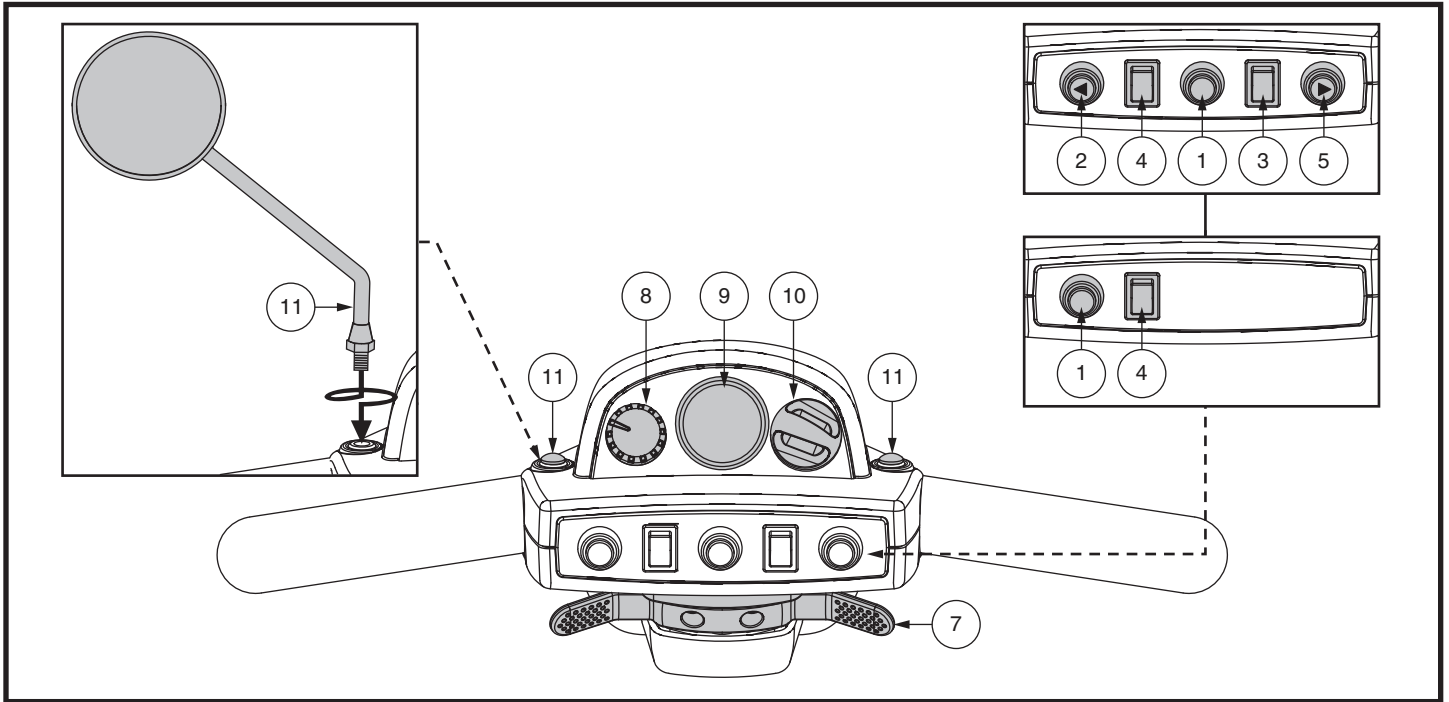

Figure 2. Tiller Console B

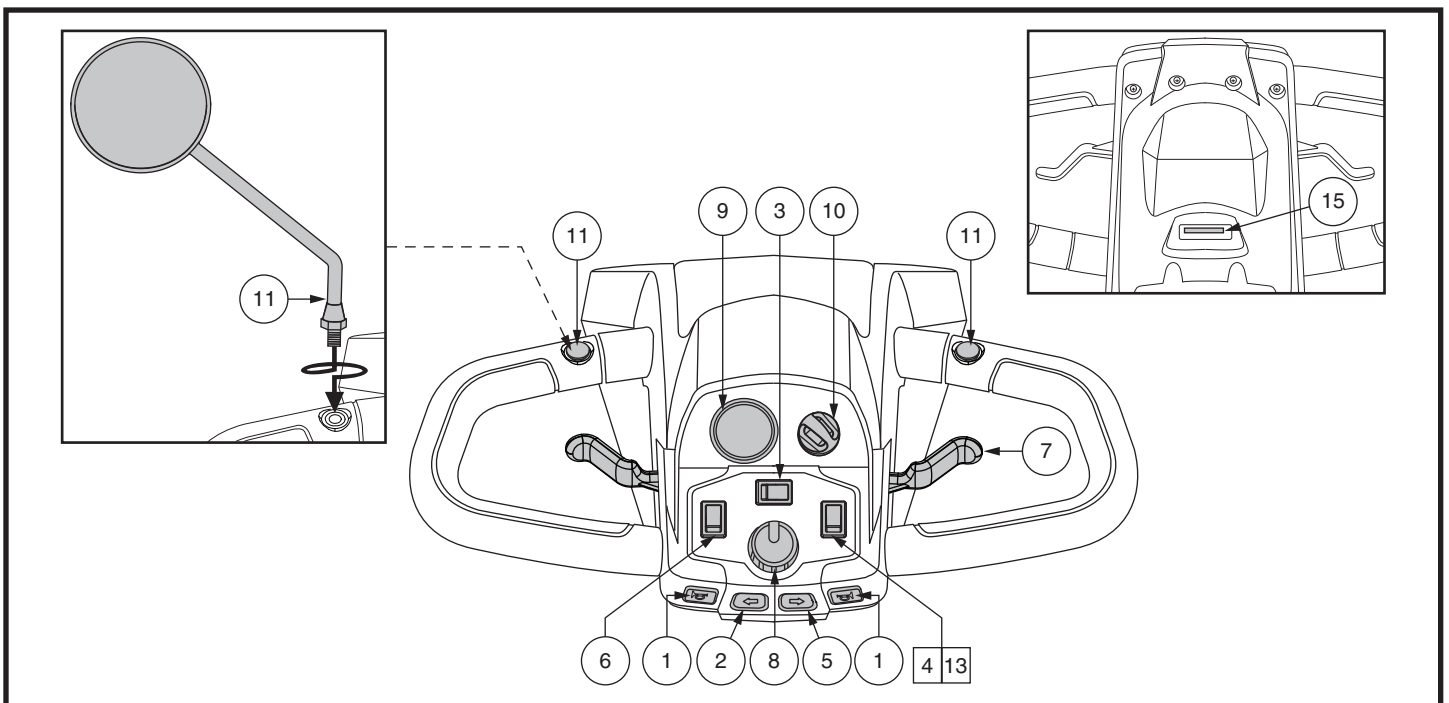

Figure 3. Tiller Console C

II. YOUR SCOOTER

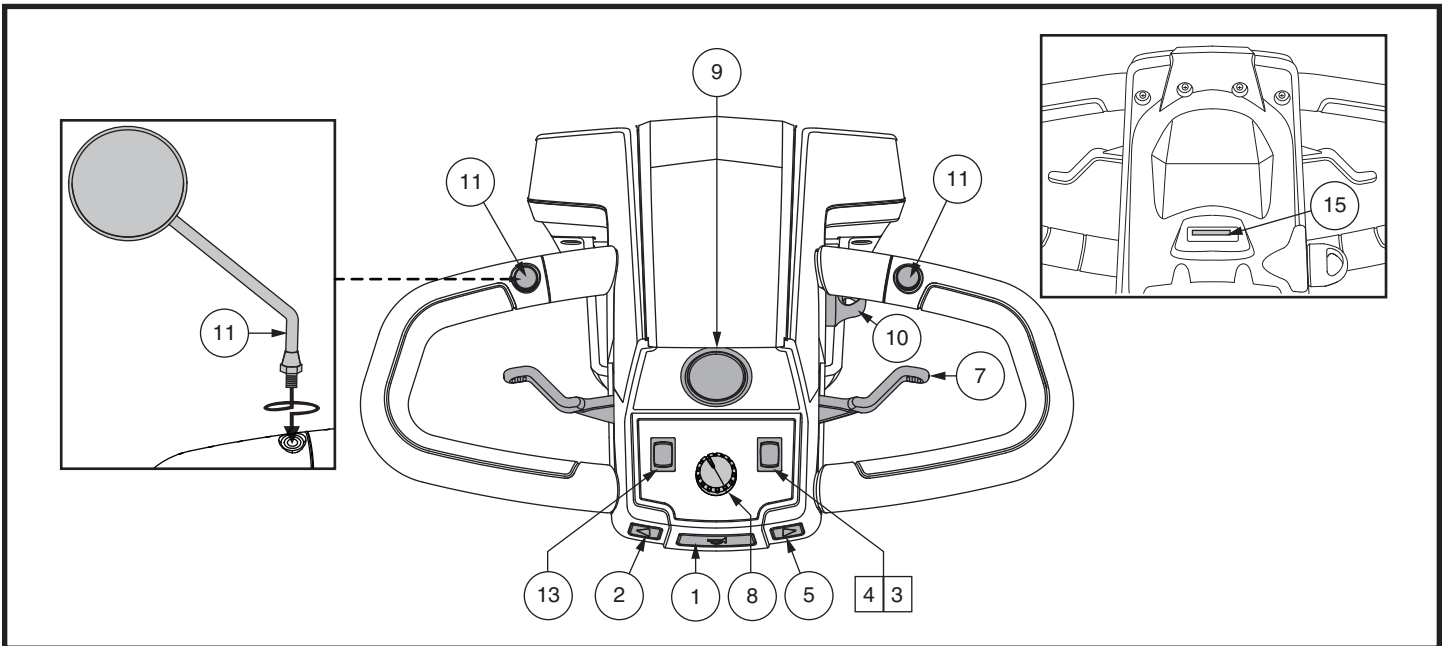

Figure 4. Tiller Console D

Horn Buttons

These buttons activate a warning horn. Your scooter must be powered up for the horn to be operational. Do not hesitate to use the warning horn when doing so may prevent accident or injury.

Turn Signal Buttons

Use these buttons to turn on the left and right turn signal (amber) lights.

- Push the left button to activate the left turn signal light. The turn signal indicator LED located in the battery condition meter will flash.
- Push the right button to activate the right turn signal light. The turn signal indicator LED located in the battery condition meter will flash.
- The turn signals are timed to shut off automatically.

Lights Switch

To operate light switch for models equipped with Tiller Console A, C, and D:

- Toggle the switch forward to turn on the front lower light.
- Return switch to center position to deactivate lights.

To operate light switch for models equipped with Tiller Console B:

- Toggle the switch forward to turn on the front lower light.
- Toggle switch rearward to deactivate lights.

Puddle Light

Some models are equipped with a puddle light. (Refer to the Scooter Features Table on the inside of the front cover for availability.)

To operate puddle light for models equipped with Tiller Console A and C:

- Toggle switch rearward to activate the puddle light.
- Return switch to center position to deactivate lights.

To operate puddle light for models equipped with Tiller Console D:

- Toggle the switch forward to activate the puddle light.
- Toggle switch rearward to deactivate the puddle light.

II. YOUR SCOOTER



WARNING! Scooter users are required to use their lights when visibility is restricted—day or night.

Hazard Lights Switch ▲

This switch activates the 4-way flashers on your scooter.

To operate hazard lights for models equipped with Tiller Console A and B:

- Toggle the switch forward to turn on the flashers.
- Toggle the switch rearward to turn off the flashers.

To operate hazard lights for models equipped with Tiller Console C:

- Toggle the switch to the right to turn on the flashers.
- Toggle the switch to the left to turn off the flashers.

To operate hazard lights for models equipped with Tiller Console D:

- Toggle the switch rearward to activate the flashers.
- Return switch to center position to deactivate flashers.

Hi-Low Switch

This switch toggles the scooter's speed between Hi and Low. Toggle the switch forward (Hi) to achieve the maximum preprogrammed speed for the scooter. Toggle the switch rearward (Low) to achieve half the maximum preprogrammed speed of the scooter.

Power Seat Switch (If Equipped)

The power seat switch activates the power seat actuator and enables you to raise and lower the seat automatically. Refer to VI. "Comfort Adjustments" for more information regarding power seat operation and safety.

Throttle Control Lever

This lever allows you to control the forward speed and the reverse speed of your scooter up to the maximum speed you preset with the speed adjustment dial.

***NOTE:** The throttle control lever operation instructions outlined below apply to scooters in a standard configuration. If the programming of your scooter was modified in any way by a provider, contact that provider for correct throttle control level operation instructions.*

To use throttle control lever for models equipped with Tiller Console A, C, and D:

To move Forward, use either of the following:

- Use your left thumb to push the left side of the throttle control lever.
- Use your right hand fingers to pull back on the right side of the throttle control lever.

To move Rearward, use either of the following:

- Use your right thumb to push the right side of the throttle control lever.
- Use your left hand fingers to pull backward on the left side of the throttle control lever.

To use throttle control lever for models equipped with Tiller Console B:

- To move **Forward**, use your right thumb to push the right side of the throttle control lever.
- To move **Rearward**, use your left thumb to push the left side of the throttle control lever.

Release the throttle control lever and allow your scooter to come to a complete stop before engaging the other side of the lever. When the throttle control lever is completely released, it automatically returns to the center "stop" position and engages your scooter's brakes.

II. YOUR SCOOTER

Speed Adjustment Dial

This dial allows you to preselect and limit your scooter's top speed.

- The image of the tortoise represents the slowest speed setting.
- The image of the hare represents the fastest speed setting.

For model 710ZT, the speed adjustment dial has three (3) speed control settings:

- The image of the leaf (ECO) represents the slowest speed setting.
- The image of the man (EV) represents the fast speed setting.
- The image of the flag (SPORT) represents the fastest speed setting.

Battery Condition Meter

When the key is fully inserted and turned clockwise to power up your scooter, this meter indicates the approximate battery voltage strength. For further information on battery charging, see III. "Batteries and Charging."

Status LED (If Equipped)

The status LED alerts you to electrical problems that may occur with the scooter. The LED remains constantly lit while your scooter is on. If your scooter develops an electrical problem, the status LED will flash a code. See VII. "Basic Troubleshooting" for flash codes.

Key Switch

- Insert the key into the key switch and turn it clockwise to power up (turn on) your scooter.
- Turn the key counterclockwise to power down (turn off) your scooter.



WARNING! If the key is turned to the "off" position while your scooter is in motion, the electronic brakes will engage and your scooter will come to an abrupt stop.

Mirror Positioning and Adjustment

For information on positioning and adjusting your mirror, see V. "Comfort Adjustments."

Handbrake Lever (If Equipped)

This lever provides you with emergency stopping power. When in motion, release the throttle control lever and gently squeeze the handbrake lever to come to a stop.

The handbrake can be locked and used as a parking brake by squeezing the handbrake lever fully and moving the brake lock to the locked position. See figure 1. To release the brake lock, fully squeeze the handbrake.



WARNING! The handbrake is intended for use as an emergency brake and/or parking brake only.

Off-board Charger Port

The off-board charger power cord plugs into this port during battery charging. The off-board charger port is located on the tiller. See figure 5.

Electrical System Fuses

Your scooter is equipped with a series of electrical system fuses, which help protect the off-board charging system, key switch and lighting system from receiving an overload of electrical current. These fuses are the same type used in automobiles and are located in a compartment on the tiller. See figure 5. See VIII. "Care and Maintenance" for fuse replacement.

NOTE: Keep all electrical areas clean and free of moisture and foreign material.

IDENTIFICATION KEY

1. OFF-BOARD CHARGER PORT
2. OFF-BOARD CHARGER FUSE
3. KEY SWITCH FUSE
4. LOWER HEADLIGHT FUSE
5. REAR TAIL LIGHTS FUSE
6. LEFT TURN SIGNAL FUSE
7. RIGHT TURN SIGNAL FUSE

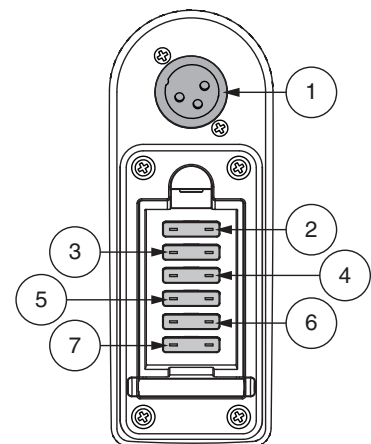

Figure 5. Off-board Charger Port/Tiller Console Fuses

II. YOUR SCOOTER

REAR COMPONENTS

The manual freewheel lever, anti-tip wheels, motor/transaxle assembly, and optional safety flag brackets are located on your scooter as shown. See figure 6. Although not shown, the batteries and main circuit breaker (reset button) are also located on the rear component section of your scooter.



WARNING! Before placing your scooter into or taking it out of freewheel mode, remove the key from the key switch. Never sit on a scooter when it is in freewheel mode. Never put a scooter in freewheel mode on any incline.

Manual Freewheel Lever

Whenever you need or want to push your scooter for short distances, you can put it in freewheel mode.

1. Remove the key from the key switch.
2. Push forward on the manual freewheel lever to disable the drive system and the brake system. This will enable you to push the scooter.

NOTE: If your scooter is equipped with a 2-position manual freewheel lever, you must pull up on the lever and then push forward on the manual freewheel lever to disable the drive system and the brake system. This will enable you to push the scooter.

3. Pull back on the manual freewheel lever to reengage the drive and the brake systems and take your scooter out of freewheel mode.

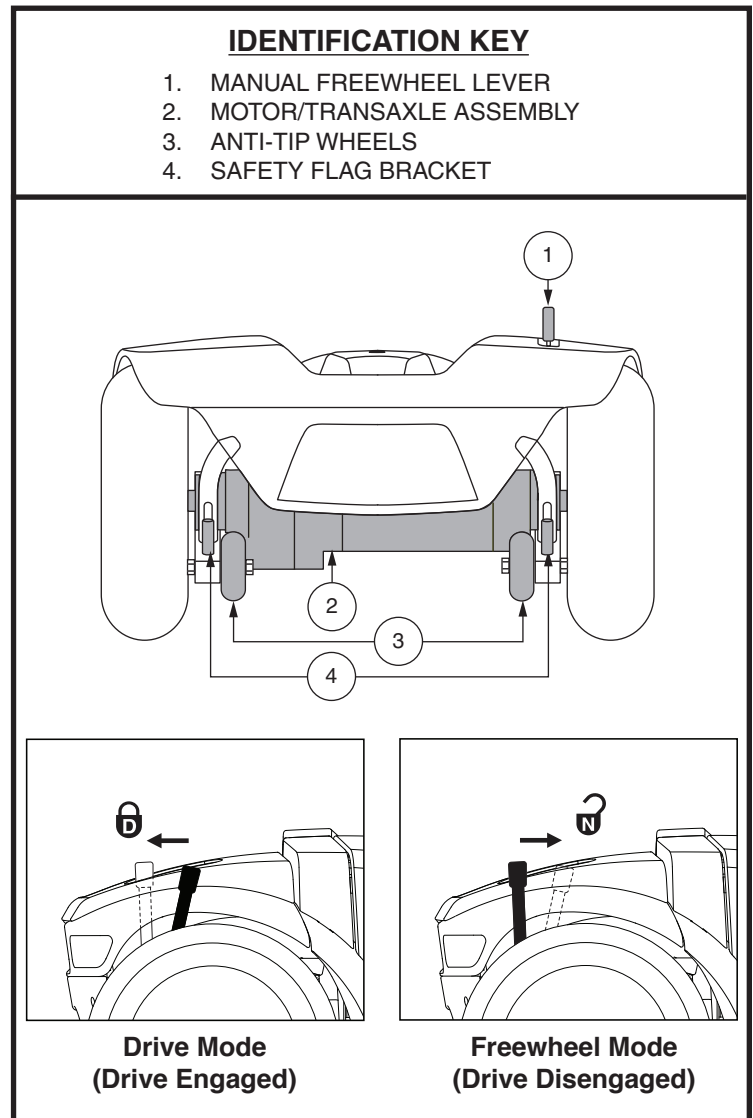

Figure 6. Rear Components



WARNING! When your scooter is in freewheel mode, the braking system is disengaged.

- Disengage the drive motors only on a level surface.
- Ensure the key is removed from the key switch.
- Stand to the side of the scooter to engage or disengage freewheel mode. Never sit on a scooter to do this.
- After you have finished pushing your scooter, always return it to the drive mode to lock the brakes.

NOTE: If the scooter is placed in freewheel mode (manual freewheel lever forward) while the key is in the “on” position, the scooter will not run until the manual freewheel lever is pushed rearward and the key is turned to the “off” position, then back to the “on” position.

II. YOUR SCOOTER

IDENTIFICATION KEY

1. MANUAL FREEWHEEL LEVERS
2. MOTOR/TRANSAXLE ASSEMBLY
3. ANTI-TIP WHEELS

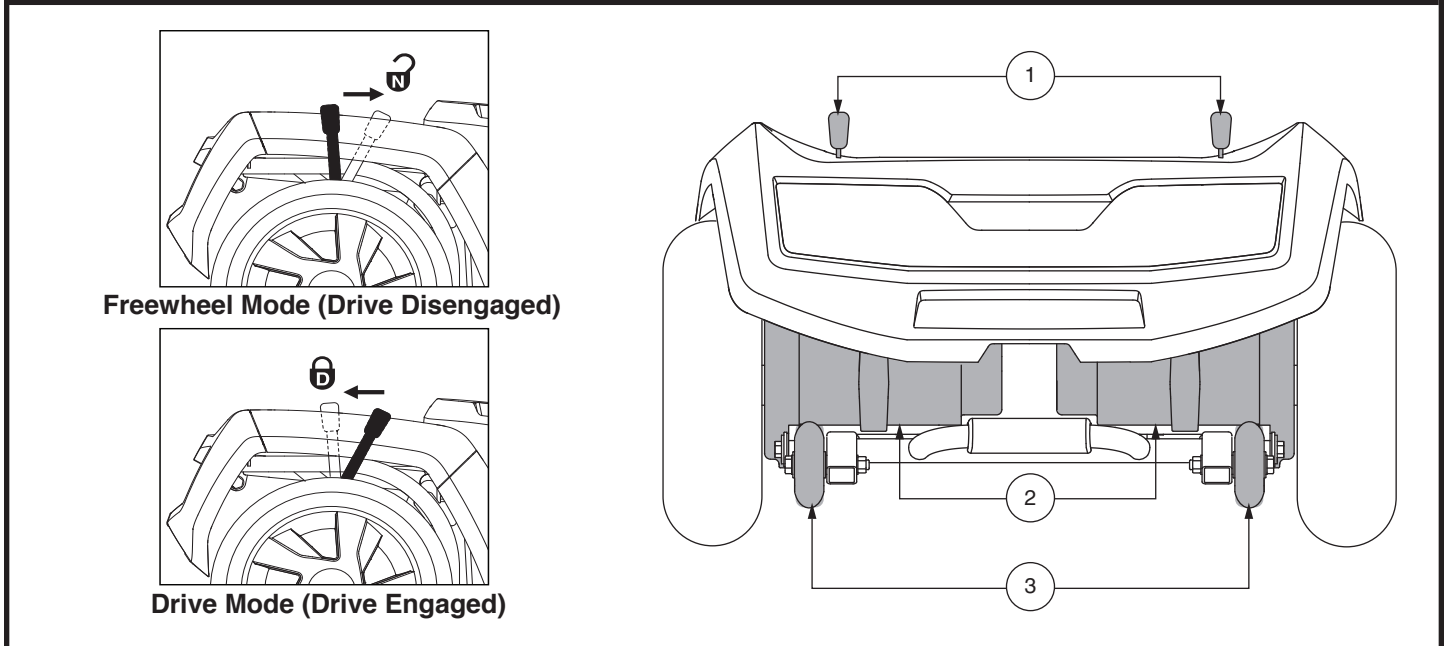

Figure 7. Rear Components - 710ZT

Manual Freewheel Levers - 710ZT

For your convenience, your scooter has a manual freewheel lever on each motor. Manual freewheel levers enable you to disable the drive system in order to maneuver the scooter manually. See figure 7.



WARNING! Do not use the scooter while the drive motors are disengaged! Do not disengage the drive motors when the scooter is on an incline or decline, as the unit could roll on its own! Only engage the freewheel mode when on a level surface.

WARNING! It is important to remember that when your scooter is in freewheel mode, the braking system is disengaged.

NOTE: It is strongly recommended that you do not charge your batteries while in freewheel mode.

NOTE: You must turn off the power before disabling the drive systems; otherwise, you may get an error code on the scooter. To clear this code, turn off the scooter and place the scooter in drive mode. Then turn on the scooter. The error message should be cleared. If not, contact an authorized Provider.

To engage or disengage the drive system:

1. Locate the levers on the rear section of the scooter. See figure 7.
2. Pull the two levers toward the front of the scooter to disengage the drive motors (freewheel mode).
3. Push the two levers toward the rear of the scooter to engage the drive motors (drive mode).

If a lever is difficult to move in either direction, rock your scooter back and forth slightly. The lever should then move to the desired position.



WARNING! Do not use the freewheel lever handles as tie-down points to secure this product.

II. YOUR SCOOTER

Motor/Transaxle Assembly

The motor/transaxle assembly is an electromechanical unit that converts electrical energy from your scooter's batteries into the controlled mechanical energy that drives the scooter's wheels.

Anti-Tip Wheels

The anti-tip wheels are an integral and important safety feature of your scooter. They are bolted to the frame at the rear of the scooter.



PROHIBITED! Do not remove the anti-tip wheels or modify your scooter in any way that is not authorized by your Provider.



WARNING! The anti-tip wheels may cause interference with the smooth transition of your scooter when ascending or descending a curb. Contact your authorized Provider for more information.

Storage Compartment (If Equipped)

Storage compartment is located in your Scooter's tiller for the convenient storage of personal items.



WARNING! No personal property, pets, electronics or valuables should be stored in storage compartment and left unattended.

Batteries

The batteries store electrical energy that powers your scooter. See III. "Batteries and Charging" for information on how to charge your scooter batteries.

Safety Flag Bracket (Optional)

An accessory bracket for installing an optional safety flag is mounted near each anti-tip wheel. See figure 6. To install the flag, the supplied L-shaped hex key is needed.

To install the safety flag:

1. Remove the cap from the top of the bracket.
2. Loosen the setscrew with the supplied L-shaped hex key.
3. Insert the flag pole into the opening.
4. Tighten the setscrew to complete installation.

Main Circuit Breaker (Reset Button)

When the voltage in the batteries becomes low or your scooter is heavily strained because of excessive loads, the main circuit breaker may trip to protect the motor and electronics from damage. When the breaker trips, the entire electrical system shuts down. See figure 8.

- The reset button pops out when the breaker trips.
- Allow a minute or so for the electronics to "rest."
- Push in the reset button to reset the breaker.
- If the breaker trips frequently, you may need to charge the batteries more often or have your authorized Provider perform a load test on the batteries.
- If the main circuit breaker trips repeatedly, see your authorized Provider for service.

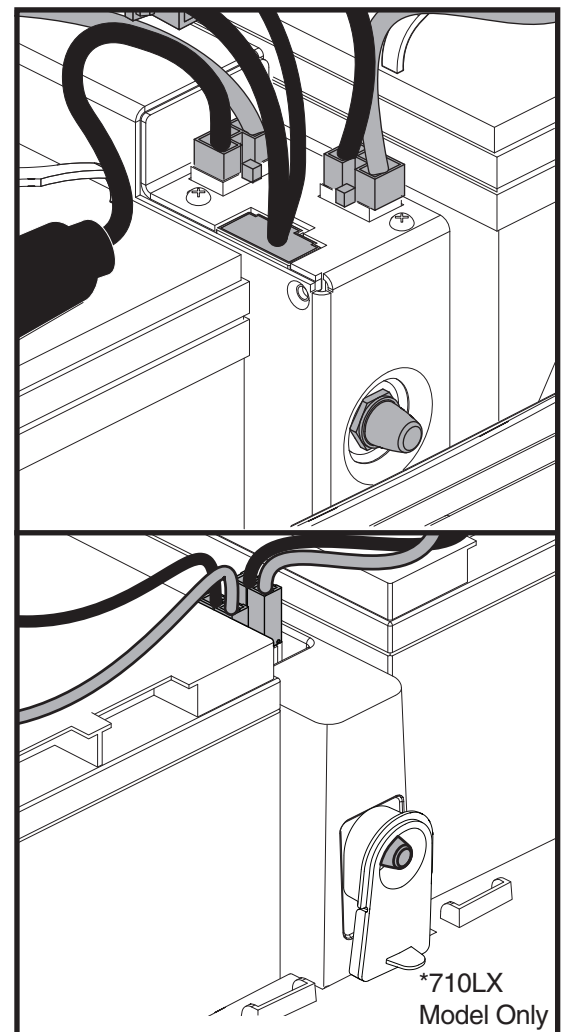

Figure 8. Main Circuit Breaker (Reset Button)

II. YOUR SCOOTER

SECURING THE SCOOTER

Always secure the scooter in a forward-facing position in the vehicle. Attach the four tie-down straps to the designated securement points. See figures 9 and 10. Tighten the straps to sufficiently remove all slack. Never attach tie-downs to adjustable, moving or removable parts of the scooter such as armrests, shrouds, and wheels. Any removable items should be removed and stowed separately. Position the anchor points for the rear tie-down straps directly behind the rear securement points on the scooter. The front tie-down straps should anchor to floor points that are spaced wider than the scooter to provide increased lateral stability.

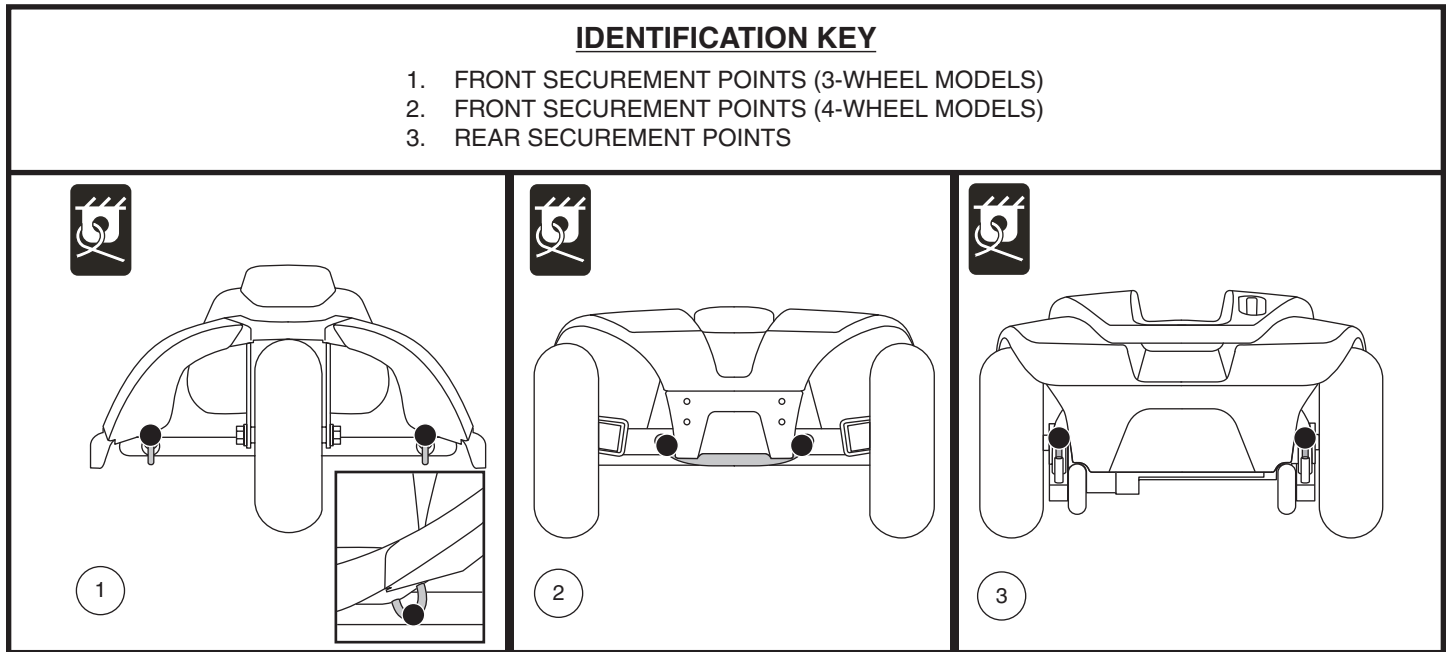

Figure 9. Securement Points (Identified with black dots)



WARNING! Ensure scooters are properly secured to the motor vehicle during transport. Scooters that are not properly secured can become a hazard to the user and to other vehicle passengers in the event of a crash, sudden stopping, or swerving, as the scooter could tip or slide out of place. Do not secure a scooter by any of its removable parts such as armrests, seat, basket, accessory brackets, etc.

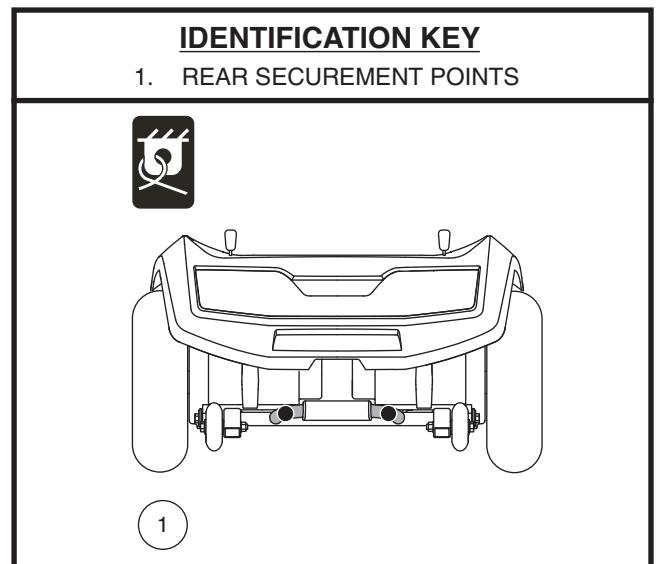

Figure 10. 710ZT - Securement Points (Identified with black dots)

III. BATTERIES AND CHARGING

BATTERIES AND CHARGING

Your scooter requires two long-lasting, 12-volt, deep-cycle batteries that are sealed and maintenance free. They are recharged by an off-board charging system.

- Charge your scooter's batteries for at least 8 to 14 hours prior to using it for the first time.
- Keep the batteries fully charged to keep your scooter running smoothly.

READING YOUR BATTERY VOLTAGE

The battery condition meter on the tiller console indicates the approximate strength of your batteries using a color code. From right to left, green indicates fully charged batteries, yellow indicates a draining charge and red indicates that an immediate recharge is necessary. See **figure 11**. To ensure the highest accuracy, the battery condition meter should be checked while operating your scooter at full speed on a dry, level surface.

NOTE: Ambient Meter (Battery Condition Meter 1c) adjusts brightness based on environmental lighting.

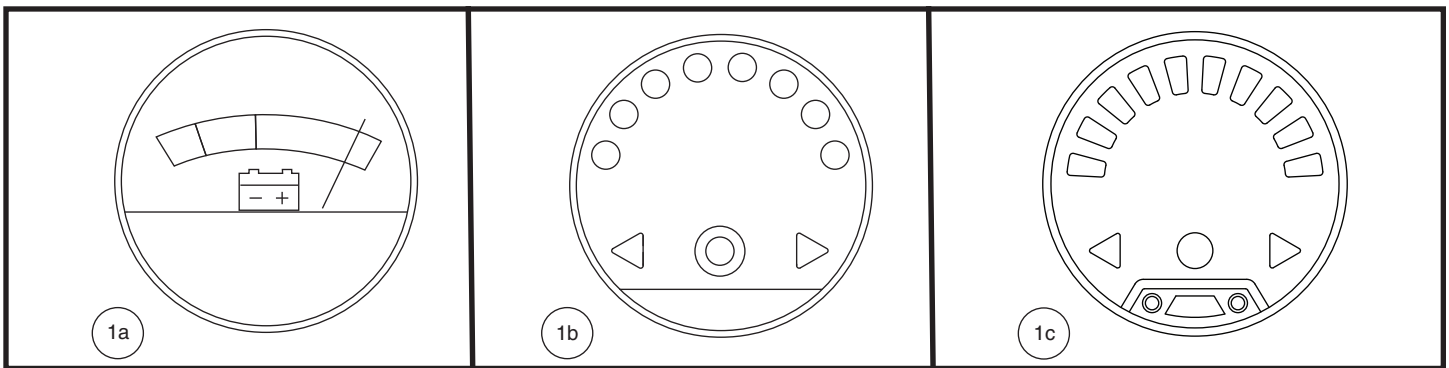

Figure 11. Battery Condition Meter

CHARGING YOUR BATTERIES



PROHIBITED! Removal of grounding prong can create electrical hazard. If necessary, properly install an approved 3-pronged adapter to an electrical outlet having 2-pronged plug access.



PROHIBITED! Never use an extension cord to plug in your battery charger. Plug the charger directly into a properly wired standard electrical outlet.



PROHIBITED! Do not allow unsupervised children to play near the scooter while the batteries are charging. We recommend that you do not charge the batteries while the scooter is occupied.



MANDATORY! Read the battery charging instructions in this manual and in the manual supplied with the battery charger before charging the batteries.



WARNING! Explosive gases may be generated while charging the batteries. Keep the scooter and battery charger away from sources of ignition such as flames or sparks and provide adequate ventilation when charging the batteries.

WARNING! You must recharge your scooter's batteries with the supplied off-board charger. Do not use an automotive-type battery charger.



WARNING! Inspect the battery charger, wiring and connectors for damage before each use. Contact your authorized Provider if damage is found.

WARNING! Do not attempt to open the battery charger case. If the battery charger does not appear to be working correctly, contact your authorized Provider.

III. BATTERIES AND CHARGING



WARNING! If the battery charger is equipped with cooling slots, then do not attempt to insert objects through these slots.



WARNING! Be aware that the battery charger case may become hot during charging. Avoid skin contact and do not place on surfaces that may be affected by heat.



WARNING! If your battery charger has not been tested and approved for outdoor use, then do not expose it to adverse or extreme weather conditions. If the battery charger is exposed to adverse or extreme weather conditions, then it must be allowed to adjust to the difference in environmental conditions before use indoors. Refer to the manual supplied with the battery charger for more information.

Follow the 6 easy steps in figure 12 to charge your batteries safely:

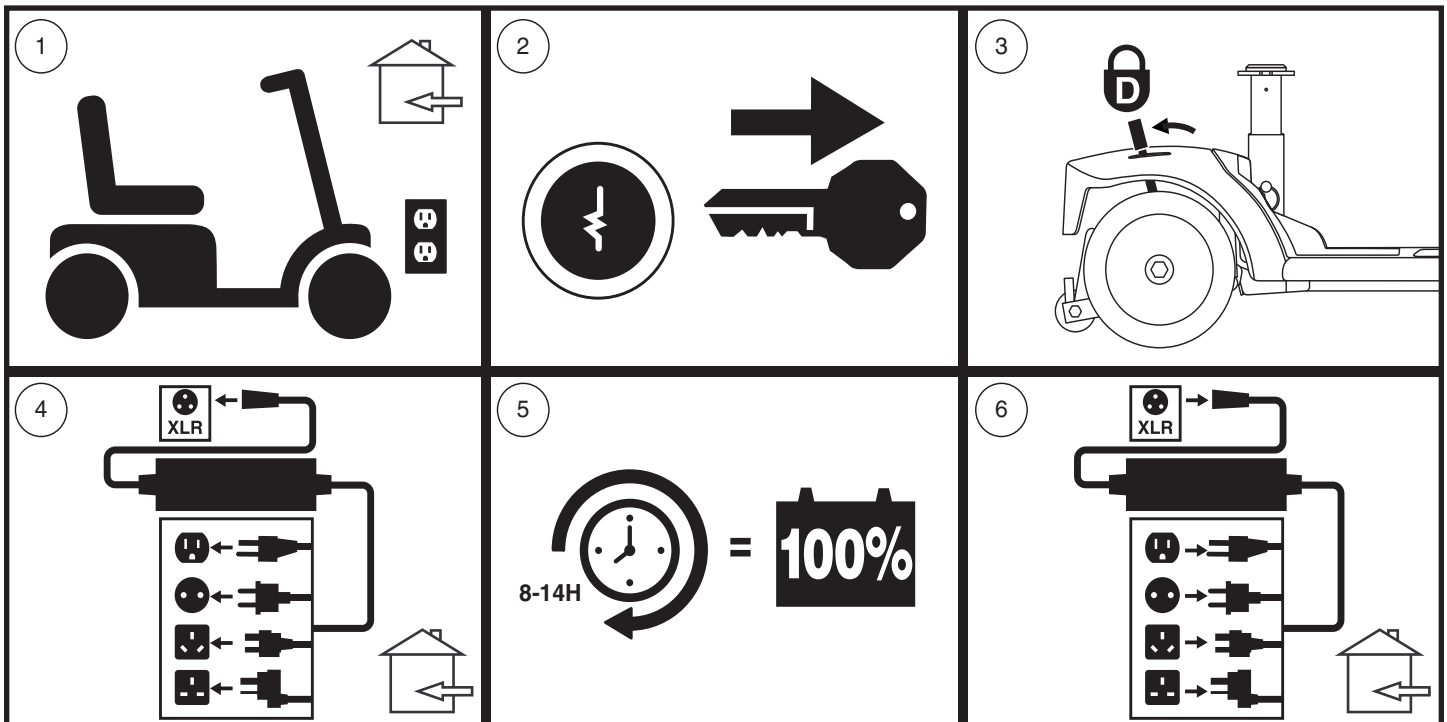

Figure 12. Battery Charging Procedures Diagram

NOTE: For model 710ZT, the manual freewheel levers operate in the opposite direction (see figure 7). Therefore, for step 3 of figure 12, the levers must be pushed forward to engage drive mode.



WARNING! The LED lights on the charger indicate different charger conditions at various times. If the LED does not indicate that charging is complete within 24 hours, unplug the charger from the outlet and contact your Provider. Refer to the operating instructions supplied with the charger for a complete explanation of these indicators.

NOTE: There is a charger inhibit function on your scooter. The scooter will not run and the battery condition meter will not operate while the batteries are charging.

FREQUENTLY ASKED QUESTIONS

How does the charger work?

When your scooter's battery voltage is low, the charger works harder, sending more electrical current to the batteries to bring up their charge. As the batteries approach a full charge, the charger sends less and less electrical current. When the batteries are fully charged, the current sent from the charger is at nearly zero amperage. Therefore, when the charger is plugged in, it maintains the charge on your scooter's batteries, but does not overcharge them. Refer to the manual supplied with the battery charger for charging instructions.

III. BATTERIES AND CHARGING

Can I use a different charger?

Chargers are selected precisely for particular applications and are especially matched to the type, size and chemical formulation of specific batteries. For the safest and most efficient charging of your scooter's batteries we recommend only use of the charger supplied as original equipment with your product. Any charging method resulting in batteries being charged individually is especially prohibited.

What if my scooter's batteries won't charge?

- Ensure the red (+) and black (-) battery cables are connected properly to the battery terminals.
- Ensure both battery harnesses that extend from the batteries are plugged into their mating harness leading to the charger.
- Ensure both ends of the charger power lead are inserted fully.
- Ensure the charger fuse on the tiller is not blown. **See figures 5 and 31.**

How often must I charge the batteries?

Two major factors must be considered when deciding how often to charge your scooter's batteries:

- All day scooter use on a daily basis.
- Infrequent or sporadic scooter use.

With these considerations in mind, you can determine how often and for how long you should charge your scooter's batteries. The battery charger was designed so that it will not overcharge your scooter's batteries. However, you may encounter some problems if you do not charge your batteries often enough and if you do not charge them on a regular basis. Following the guidelines below will provide safe and reliable battery operation and charging.

- If you use your scooter daily, charge its batteries as soon as you finish using it for the day. Your scooter will be ready each morning. We recommend that you charge your scooter's batteries for at least 8 to 14 hours after daily use. We recommend that you charge the batteries for an additional 4 hours after the battery charger indicates that charging is complete.
- If you use your scooter once a week or less, charge its batteries at least once a week for at least 24 hours.

NOTE: Keep your batteries fully charged and avoid deeply discharging your batteries. Refer to the manual supplied with the battery charger for charging instructions. We recommend charging your batteries for at least 48 continuous hours once per month to improve battery performance and battery life.

How can I get maximum range or distance per charge?

Rarely will you have ideal driving conditions—smooth, flat, hard driving surfaces with no wind or curves. Often, you will face hills, pavement cracks, uneven and loosely packed surfaces, curves and wind, all of which affect the distance or running time per battery charge. Below are a few suggestions for obtaining the maximum range per battery charge.

- Always fully charge your scooter's batteries prior to daily use.
- Maintain but do not exceed the psi/bar/kPa air pressure rating indicated on each tire.
- Plan your route ahead to avoid as many hills, cracked, broken or soft surfaces as possible.
- Limit your baggage weight to essential items.
- Try to maintain an even speed while your scooter is in motion.
- Avoid stop-and-go driving.
- We recommend charging your batteries for at least 48 continuous hours once per month to improve battery performance and battery life.
- Make sure all harness connections are secured properly.

How can I ensure maximum battery life?

Fully charged deep-cycle batteries provide reliable performance and extended battery life. Keep your scooter's batteries fully charged whenever possible. Protect your scooter and batteries from extreme heat or cold. Batteries that are regularly and deeply discharged, infrequently charged, stored in extreme temperatures or stored without a full charge may be permanently damaged, causing unreliable performance and limited service life.

III. BATTERIES AND CHARGING

NOTE: To extend battery life, always turn off scooter and remove the key when not in use.

What type and size of battery should I use?

We recommend deep-cycle batteries that are sealed and maintenance free. Both AGM and Gel-Cell are deep-cycle batteries that are similar in performance. Do not use wet-cell batteries, which have removable caps. Refer to the specifications table for size as batteries differ depending on manufacturer.



WARNING! Corrosive chemicals are contained in batteries. Use only AGM or Gel-Cell batteries to reduce the risk of leakage or explosive conditions.

NOTE: Sealed batteries are not serviceable. Do not remove the caps.

Why do my new batteries seem weak?

Deep-cycle batteries employ a different chemical technology than that used in car batteries, nickel-cadmium batteries (nicads) and other common battery types. Deep-cycle batteries are specifically designed to provide power, drain down their charge and then accept a relatively quick recharge.

We work closely with our battery manufacturer to provide batteries that best suit your scooter's specific electrical demands. Fresh batteries are shipped fully charged to our customers. During shipping, the batteries may encounter temperature extremes that can influence their initial performance. Heat diminishes the charge on the battery; cold slows the available power and extends the time needed to recharge the battery.

It may take a few days for the temperature of your scooter's batteries to stabilize and adjust to their new room or ambient temperature. More importantly, it takes a few charging cycles (partial draining followed by full recharging) to establish the critical chemical balance that is essential to a deep-cycle battery's peak performance and long life.

Follow these steps to properly break in your scooter's new batteries for maximum efficiency and service life:

1. Fully recharge any new battery prior to its initial use. This charging cycle brings the battery up to about 88% of its peak performance level.
2. Operate your new scooter in familiar and safe areas. Drive slowly at first and do not travel too far from your home or familiar surroundings until you have become accustomed to your scooter's controls and have properly broken in your scooter's batteries.
3. Fully recharge the batteries. They should be at over 90% of their peak performance level.
4. Operate your scooter again, and fully recharge the batteries again.
5. After four or five charging cycles, the batteries are able to receive a charge of 100% of their peak performance level and are able to last for an extended period of time.

What about public transportation?

AGM and Gel-Cell batteries are designed for application in scooters and other mobility vehicles. These batteries are Federal Aviation Administration (FAA) approved (United States only), allowing safe transportation on aircraft, buses, and trains, as there is no danger of spillage or leakage. We suggest you contact the carrier's ticket counter in advance to determine that carrier's specific requirements.

How do I change a battery in my scooter?



MANDATORY! Battery posts, terminals and related accessories contain lead and lead compounds. Wear goggles and gloves when handling batteries and wash hands after handling.



PROHIBITED! Always use two batteries of the exact same type, chemistry and amp-hour (Ah) capacity. Refer to the specifications table with this manual and in the manual supplied with the battery charger for recommended type and capacities.

III. BATTERIES AND CHARGING

WARNING! Do not mix old and new batteries. Always replace both batteries at the same time.



WARNING! Contact your authorized Provider if you have any questions regarding the batteries in your scooter.

WARNING! Do not replace the batteries while the scooter is occupied.

WARNING! The batteries on your scooter should only be serviced or replaced by an authorized Provider or a qualified technician.



PROHIBITED! Keep tools and other metal objects away from battery terminals. Contact with tools can cause electrical shock.

You may need the following to change your batteries:

- Metric/standard socket set and ratchet
- Adjustable wrench
- Screwdriver



WARNING! Do not lift beyond your physical capability. Ask for assistance when necessary while disassembling or assembling your scooter.

WARNING! Do not pull on electrical harness wires directly to detach them from the scooter. Always grasp the connector itself when disconnecting the harness to prevent wire damage.

To change batteries in your scooter:

1. Remove the seat and battery shroud. See figure 13.
2. Disconnect the battery tie-down strap. See figure 14.
3. Disconnect the battery harnesses by depressing the tabs on the battery harness connectors and pulling them straight up. See figure 14.
4. Disconnect the battery cables from the battery terminals by sliding back the terminal boots and unscrewing the nut from the bolt. See figures 15 and 16.
5. Remove the old batteries from the battery wells.
6. Place a new battery in each battery well. For 710LX and 710LXW models, face the battery terminals of each battery rearward. For all other models, face the battery terminals of each battery opposite each other and toward the outer sides of the scooter. See figure 14.
7. Connect the red battery cable to the positive (+) battery terminal on each battery.
8. Connect the black battery cable to the negative (-) battery terminal on each battery.
9. Reposition the terminal boots over the battery terminals.
10. Reconnect the battery harnesses.
11. Reconnect the battery tie-down strap.
12. Reinstall the battery shroud and seat.

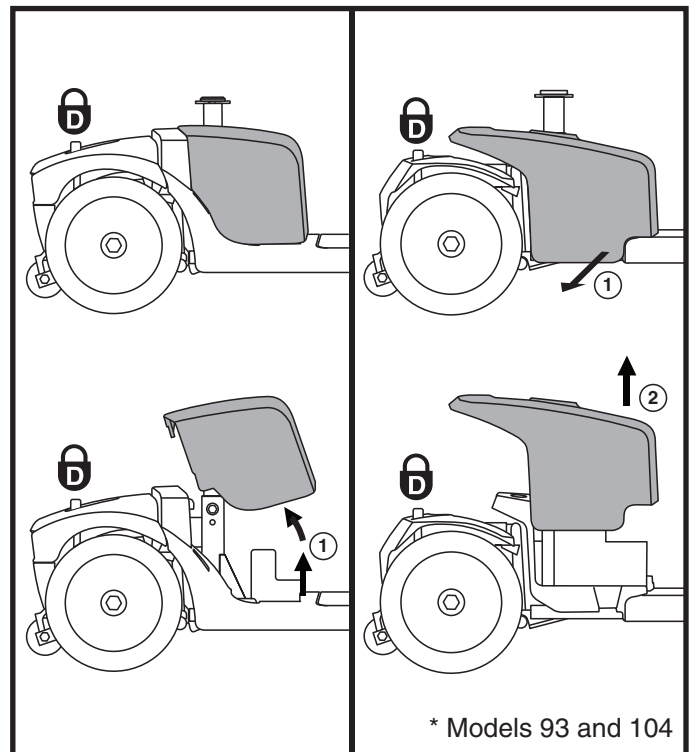

Figure 13. Battery Shroud Removal/Installation

NOTE: If you encounter a damaged or cracked battery, immediately enclose it in a plastic bag. Contact your local waste disposal agency or your authorized Provider for instructions on disposal and battery recycling, which is our recommended course of action.

III. BATTERIES AND CHARGING

IDENTIFICATION KEY

1. MAIN CIRCUIT BREAKER
2. BATTERY TERMINALS UNDER BOOTS
3. BATTERY TIE-DOWN STRAP
4. BATTERY HARNESS CONNECTORS
5. FRONT-TO-REAR HARNESS CONNECTOR

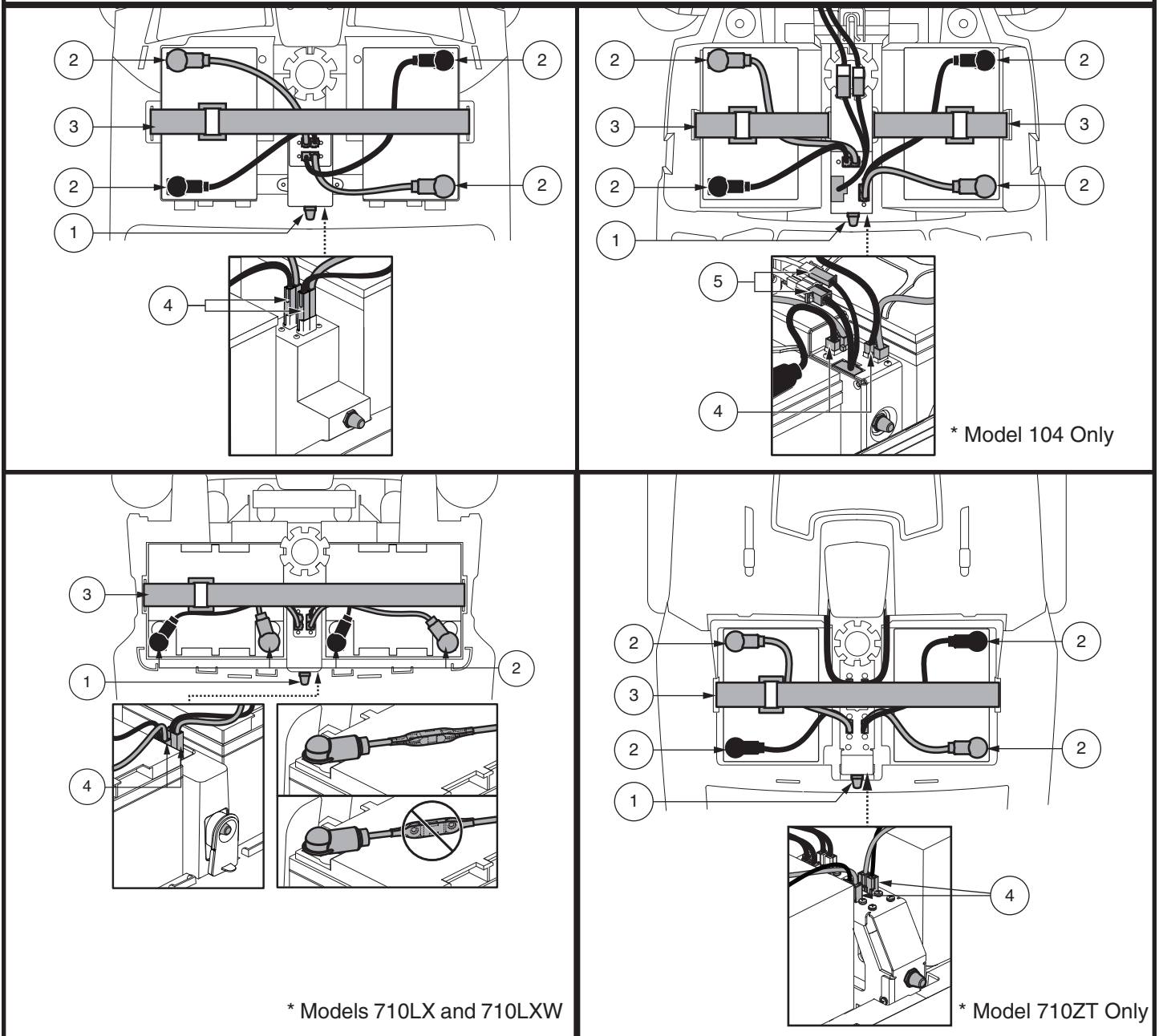

Figure 14. Battery Removal/Installation Terminals and Connections

III. BATTERIES AND CHARGING

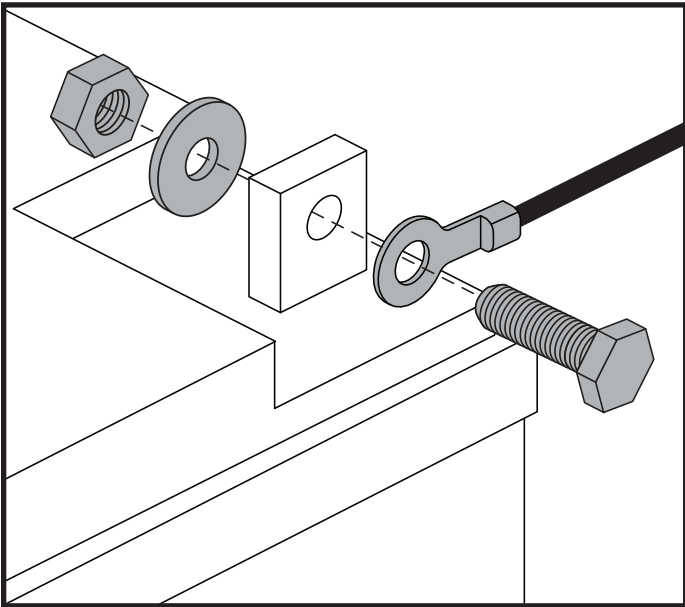

Figure 15. Battery Terminal Hardware - Configuration 1

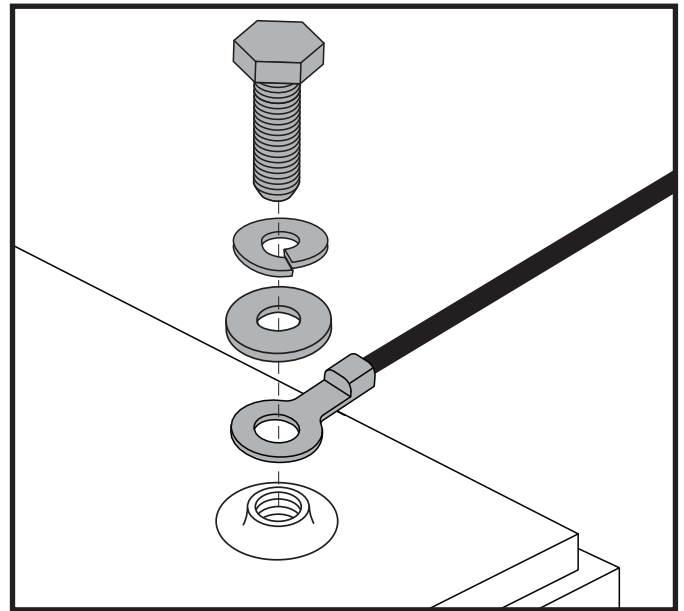

Figure 16. Battery Terminal Hardware - Configuration 2

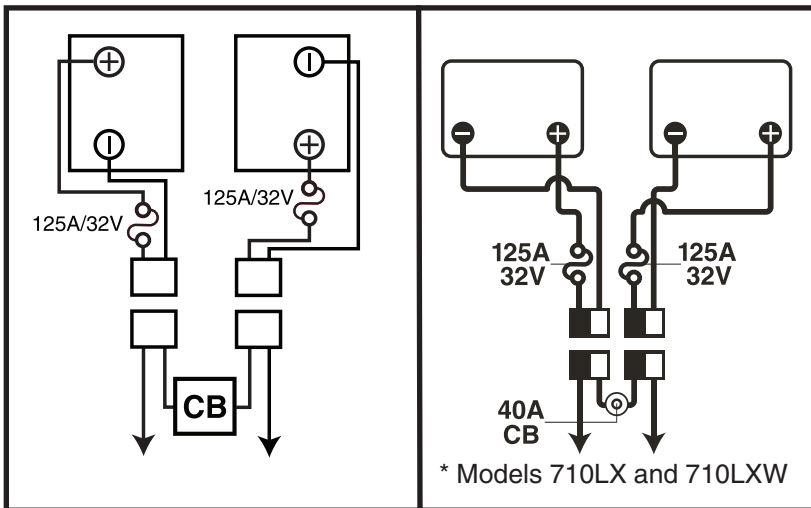

Figure 17. Battery Wiring Diagram

IV. OPERATION

BEFORE GETTING ONTO YOUR SCOOTER

- Have you fully charged the batteries? See III. “Batteries and Charging.”
- Is the manual freewheel lever in drive mode? Never leave your scooter in manual freewheel mode unless you are manually pushing your scooter.

GETTING ONTO YOUR SCOOTER

1. Make certain that the key is removed from the key switch.



WARNING! Never attempt to get onto or off of your scooter without first removing the key from the key switch. This will prevent the scooter from moving if accidental throttle control lever contact is made.

2. Stand at the side of your scooter.
3. Disengage the seat rotation lever and rotate the seat until it is facing you.
4. Make certain that the seat is secured into position.
5. Position yourself comfortably and securely in the seat.
6. Disengage the seat rotation lever and rotate the seat until you are facing forward.
7. Make certain that the seat is fixed securely in position.
8. Make certain that your feet are safely on the floorboard.

PRE-RIDE ADJUSTMENTS AND CHECKS

- Is the seat at the proper height? See V. “Comfort Adjustments.”
- Is the seat secured into place?
- Is the tiller at a comfortable setting and secured into place? See V. “Comfort Adjustments.”
- Is the key fully inserted into the key switch and turned clockwise to the “on” position?
- Does the horn work properly?
- Is your proposed path clear of people, pets, and obstacles?
- Have you planned your route to avoid adverse terrain and as many inclines as possible?

OPERATING YOUR SCOOTER



WARNING! The following can adversely affect steering and stability while operating your scooter, resulting in loss of control, tipping, and/or personal injury:

- **Holding onto or attaching a leash to walk your pet.**
- **Carrying passengers (including pets).**
- **Hanging any article from the tiller.**
- **Towing or being pushed by another motorized vehicle.**

WARNING! Keep both hands on the tiller and your feet on the floorboard at all times while operating your scooter. This driving position gives you the most control over your vehicle.

- Set the speed adjustment dial to your desired speed.
- Press your thumb against the appropriate side of the throttle control lever.
- The electromechanical disc park brake automatically disengages and the scooter accelerates smoothly to the speed you preselected with the speed adjustment dial.
- Pull on the left handgrip to steer your scooter to the left.
- Pull on the right handgrip to steer your scooter to the right.
- Move the tiller to the center position to drive straight ahead.
- To stop, slowly release the throttle control lever. The electronic brakes will automatically engage, bringing your scooter to a stop.

NOTE: Your scooter’s reverse speed is slower than that of the forward speed you preset with the speed adjustment dial.

IV. OPERATION

GETTING OFF OF YOUR SCOOTER

1. Bring your scooter to a complete stop.
2. Remove the key from the key switch.



WARNING! Never attempt to get onto or off of your scooter without first removing the key from the key switch. This will prevent the scooter from moving if accidental throttle control lever contact is made.

3. Disengage the seat rotation lever and rotate the seat until you are facing toward the side of your scooter.
4. Make certain that the seat is fixed securely in position.
5. Carefully and safely get out of the seat and stand to the side of your scooter.
6. You can leave the seat facing to the side to facilitate boarding your scooter next time.

POWER DOWN TIMER FEATURE

Your scooter is equipped with an energy saving automatic power down timer feature designed to preserve your scooter's battery life. If you mistakenly leave the key in the key switch and in the "on" position but do not use your scooter for approximately 20 minutes, the scooter's controller shuts down automatically. Although the controller is shut down, power will still be supplied to the scooter's lighting system.

If the power down timer feature takes effect, perform the following steps to resume normal operation:

1. Remove the key from the key switch.
2. Reinsert the key and power up your scooter.

V. COMFORT ADJUSTMENTS

TILLER ANGLE ADJUSTMENT (see figure 18)

WARNING! Remove the key from the key switch before adjusting the tiller or the seat. Never attempt to adjust the tiller or the seat while the scooter is in motion.



WARNING! Prior to operating the scooter, push and pull on the tiller to ensure that the angle adjustment mechanism is secure. Inspect the tiller adjustment knob and the angle adjustment mechanism to ensure that they are fully engaged. If there is movement in the tiller, check to make sure that the tiller adjustment knob is fully tightened.

NOTE: In order to fully lower the tiller for purposes of disassembly or transport, you must first completely remove the seat. See VI. “Disassembly and Assembly.”

MIRROR POSITION

To install the mirror (see figure 1, 2, 3 or 4):

1. Determine on which side to install the mirror and remove the rubber plug from the top of the tiller handle.
2. Insert the threaded end of the mirror holder into the opening and rotate it clockwise until snug.
3. If necessary, rotate the nut clockwise to secure the mirror in place.

To adjust the mirror:

1. Position yourself in a seated driving position facing forward.
2. Adjust the mirror left, right, up or down until you have a good line of sight behind you.

SEAT ADJUSTMENTS

NOTE: The seating adjustments explained in this section depend on the type of seat on your scooter. Please refer to the Scooter Features Table to determine which options apply to your specific seat type.

Armrest Width Adjustment

Your seat type may be equipped with an armrest width adjustment feature. The seat arms can be adjusted inward or outward.

1. Loosen the armrest adjustment knobs. See figure 19.
2. Use the attached ring to pull and remove the detent pins.
3. Slide the armrests in or out to the desired width.
4. Align the adjustment holes on the seat frame and armrest, then reinsert the detent pin.
5. Tighten the armrest adjustment knobs.

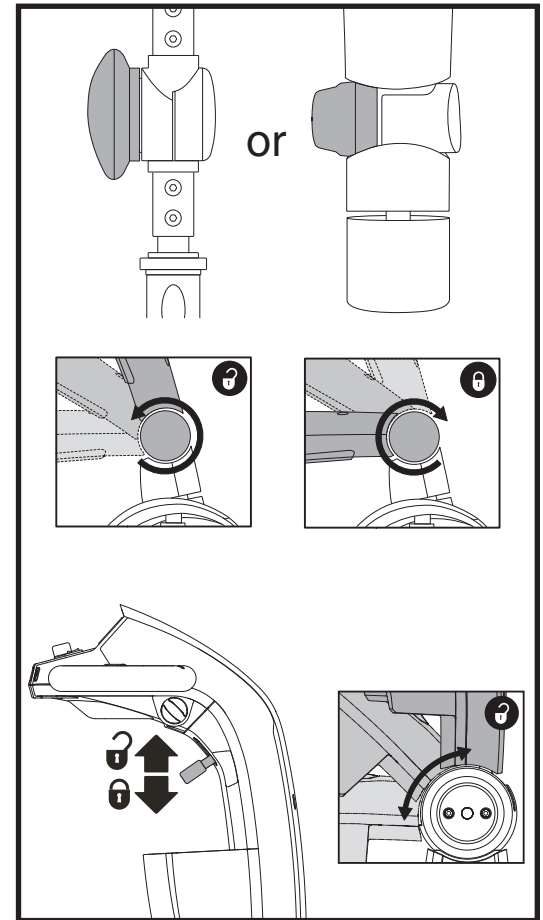

Figure 18. Tiller Adjustment Knob

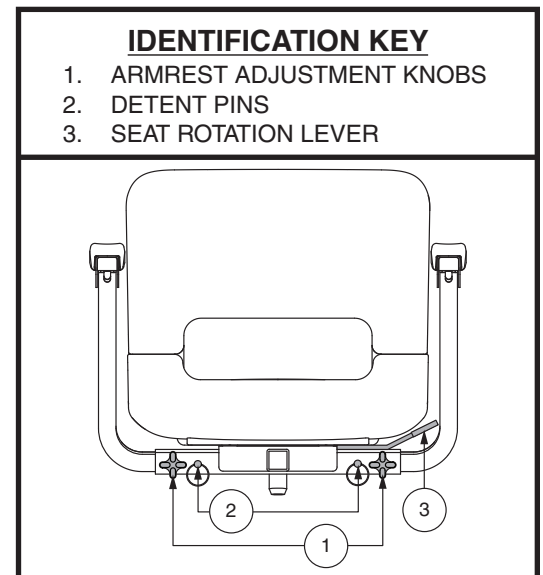

Figure 19. Seat Adjustments – Style A

V. COMFORT ADJUSTMENTS

NOTE: Pivot the armrests upward to aid in getting onto and off of your scooter.

Seat Rotation Adjustment

The seat rotation lever will secure the seat into several positions.

1. Depending on your seat type, either pull upward or push forward on the seat rotation lever to disengage the seat. See **figure 19 or 20**.
2. Rotate the seat to the desired position.
3. Release the lever to secure the seat into place.

Seatback Adjustment



WARNING! Do not operate your scooter with the seatback in a reclined position.

WARNING! Always keep your back pressed firmly against the seatback while adjusting the angle.

If your scooter is equipped with a reclining seatback, you can adjust the seatback angle with the seatback adjustment lever. See **figure 20**.

1. With your back pressed up against the seatback, lift up on the seatback adjustment lever and lean forward or rearward to adjust the seatback angle.
2. Release the seatback adjustment lever once the seat is in a comfortable riding position.

Front-to-back Seat Adjustment

If your scooter is equipped with an adjustable seat, you can reposition the seat forward or rearward to adjust the distance between the seat and the tiller.

1. Move the seat sliding lever (located at the lower left side of the seat) outward. See **figure 20**.
2. While holding the lever out, slide the seat forward or rearward.
3. Release the seat sliding lever once the seat is in the desired position.

Armrest Angle Adjustment

Armrest angle of your scooter can be adjusted upwards or downwards by turning the adjustment. See **figure 20**.

NOTE: The armrests also pivot upward to make getting on and off of your scooter easier.

Accessory Bracket

The rear-mounted accessory bracket allows you to attach a personal accessory such as a basket, walker holder, or oxygen tank to the back of your scooter. Utilize the detent pin to securely mount your item to the accessory bracket. See **figure 20**. See your authorized Provider for details.

IDENTIFICATION KEY

1. SEATBACK ADJUSTMENT LEVER
2. SEAT ROTATION LEVER
3. SEAT SLIDING LEVER
4. ACCESSORY BRACKET
5. DETENT PIN

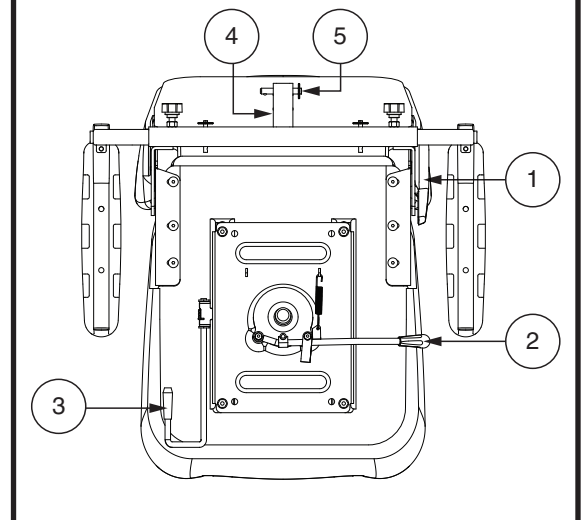

Figure 20. Seat Adjustments – Style B

V. COMFORT ADJUSTMENTS

Seat Height Adjustment

The seat can be repositioned to several different heights. See **figure 21**.

1. Remove the seat and/or shroud from your scooter. See VI. "Disassembly and Assembly."
2. Remove the seat height adjustment bolt.
3. Raise or lower the upper seat post to the desired seat height.
4. While holding the upper seat post at that height, align the adjustment holes of the upper and lower seat posts.
5. Insert the seat height adjustment bolt through the locating holes of both the upper and lower seat posts.
6. Reinstall the nut onto the seat height adjustment bolt and tighten.
7. Reinstall the shroud and the seat.

Seat Height Adjustment—Comfort Seat Post (if available)

To reposition the seat to one of two different heights:

1. Remove the seat from your scooter. Push forward or pull upward and hold the seat rotation lever to disengage the seat, then rotate the seat and lift it off of the scooter.
2. Remove the rear shroud.
3. Push up the seat post boot to uncover the hardware.
4. Push down on the seat post while loosening and removing the shoulder bolt, washer, and nut. See **figure 22**.
5. Remove the comfort spring.
6. To raise the seat to the top most mounting hole, insert the height adjustment spacer. To lower the seat to the lowest mounting hole, remove the height adjustment spacer.
7. Reinstall the comfort spring.
8. Hold the upper seat post at the desired height and match up the locating holes in the lower seat post. Utilize the top holes for the upper position or the bottom holes for the lower position.

NOTE: When the seat post is mounted in the upper position, you must utilize two spacers.

9. Press down on the seat post while reinstalling the hardware and tightening to 210 in • lb (24 N • m).
10. Replace the rear shroud and the seat.

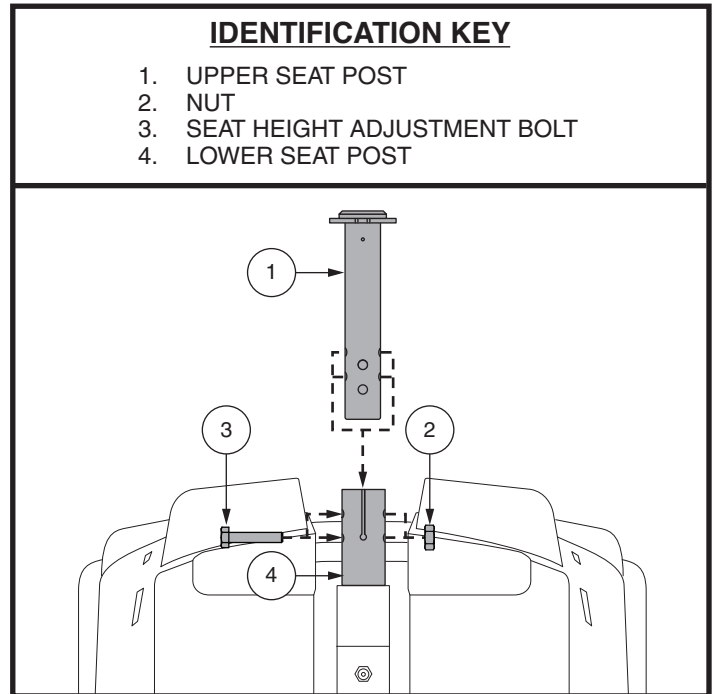

Figure 21. Seat Height Adjustment

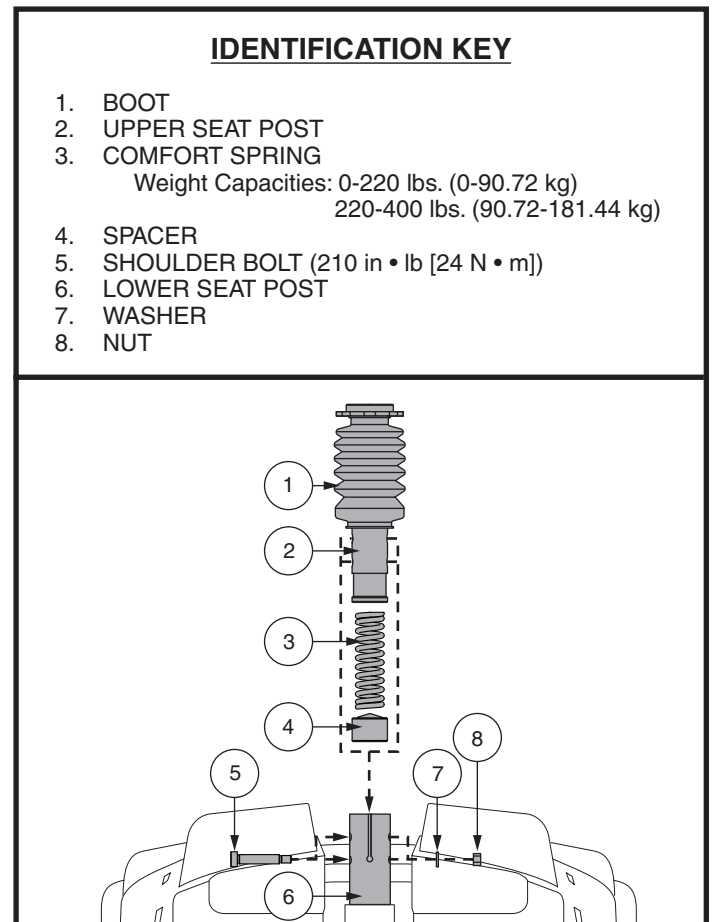

Figure 22. Seat Height Adjustment - Comfort Seat Post

V. COMFORT ADJUSTMENTS

Power Seat Adjustment (if available)

Your scooter may be equipped with a power seat. The power seat actuator is designed to raise or lower the seat with minimal effort on the part of the operator. The power seat switch is located on the tiller console.

WARNING! The power seat is intended for operation only while your scooter is stationary and on a level surface. Its purpose is to aid you in reaching objects. Drive your scooter only with the power seat in the lowest position. Driving the scooter with the power seat elevated could cause instability in the scooter, resulting in a tip or a fall.



Strict adherence to the following safety rules is vital to your safety:

- **Operate the power seat only while completely stationary on level ground.**
- **Do not press the throttle control lever and the power seat switch at the same time.**
- **Do not operate your scooter with the power seat elevated. Operate the scooter only with the power seat fully retracted (in the lowest position).**
- **Never place your scooter in freewheel mode with the power seat elevated.**
- **Use extreme caution when reaching for objects with your power seat elevated. Do not overextend or attempt to pick up objects that might affect your balance.**
- **Do not attempt to raise or lower the seat while in motion.**

Before operating the power seat, ensure your scooter is level and stationary and the speed adjustment dial is set to the slowest setting.

To operate the power seat:

1. Press and hold the upper part of the power seat switch (see **figure 1**) to raise the seat. Release the switch when you have attained your desired height or upon reaching the highest position.
2. Press and hold the lower part of the power seat switch to lower the seat. Release the switch when you have attained your desired height or upon reaching the lowest position.

NOTE: The scooter must be stopped in order for the power seat to be operated. If the power seat switch is pressed while the scooter is in motion, the scooter will slow and come to a stop. The scooter may also produce a fault code. If a fault code occurs, you will need to turn the scooter's power off, then back on again before proceeding.

Instances may occur when the power seat is raised to reach something or get a better vantage point and not returned to its lowest position before operating the scooter again. Depending on how high the power seat is raised, your scooter's speed will be reduced when operating the scooter.

Elevating the power seat to approximately one-half of its maximum height limits your scooter's speed to half that set with the speed adjustment dial. If the power seat is elevated to approximately three-quarters of its maximum height, the scooter will not move if the throttle control lever is pressed. The power seat must be lowered to slightly under three-quarters of its maximum height in order to drive the scooter again. The scooter cannot be driven at full speed until the scooter's seat is lowered to approximately one-half of its maximum height.

It is strongly recommended that the scooter not be operated with the power seat elevated.

V. COMFORT ADJUSTMENTS

Seat Suspension Adjustment (if available)

You can loosen or stiffen the seat suspension based on which comfort spring you install.

To adjust the seat suspension:

1. Remove the seat from your scooter. Push forward or pull upward and hold the seat rotation lever to disengage the seat, then rotate the seat and lift it off of the scooter.
2. Remove the rear shroud.
3. Push up the seat post boot to uncover the hardware.
4. Push down on the seat post while loosening and removing the hex head bolt and nut.
5. Remove the current spring.
6. Install the desired spring. **See figure 22.**
7. Press down on the seat post while reinstalling the hardware and tightening to 210 in • lb (24 N • m).
8. Replace the rear shroud and the seat.

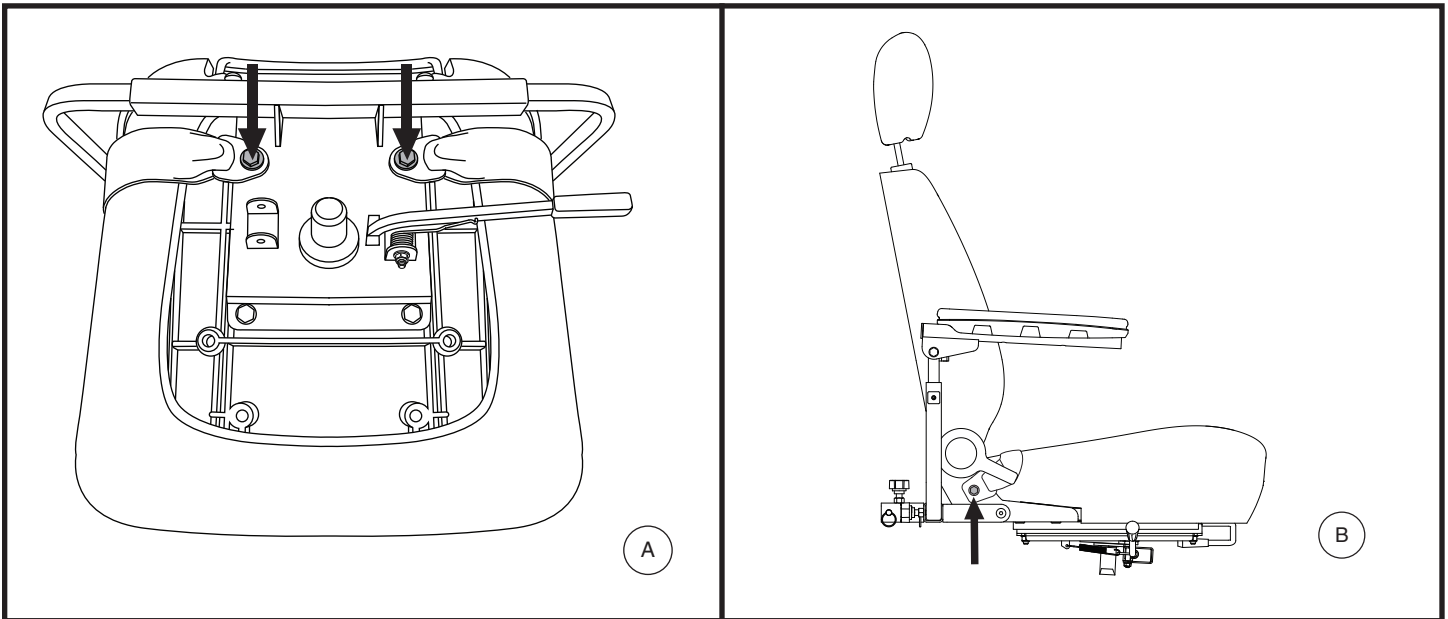

Figure 23. Positioning Belt Bolts

POSITIONING BELT (OPTIONAL)

Your scooter seat may be equipped with a positioning belt that can be adjusted for operator comfort. **See figure 23.** The positioning belt is designed to help support the operator so that he or she does not slide down or forward in the seat. The positioning belt is not designed for use as a restraining device.



WARNING! The positioning belt is not designed for use as a seat belt in a motor vehicle. Nor is your scooter suitable for use as a seat in any vehicle. Anyone traveling in a vehicle should be properly belted into seats approved by the vehicle manufacturer.

WARNING! The positioning belt should be secured at all times. Never allow the positioning belt to hang or drag on the floor as it may become entangled.

V. COMFORT ADJUSTMENTS

To install the positioning belt (if required):

1. Remove the seat from your scooter.
2. Place the seat upside down so that you can see the bottom of the seat base. See figure 23.
3. Use a wrench to remove the two rear bolts that attach the seat frame to the seat base.
4. Insert the bolt through the appropriate ends of the positioning belt and then reinstall the bolts back into the seat frame.
5. Tighten the bolts.

Metal tab style positioning belt

To adjust the positioning belt for operator comfort:

1. Insert the metal tab on the right side of the belt into the plastic housing on the opposite strap until you hear a “click.” See figure 24.
2. Pull the strap on the right side of the belt until it is secure, but not so tight as to cause discomfort.

To release the positioning belt:

1. Press the push button mechanism on the plastic housing.

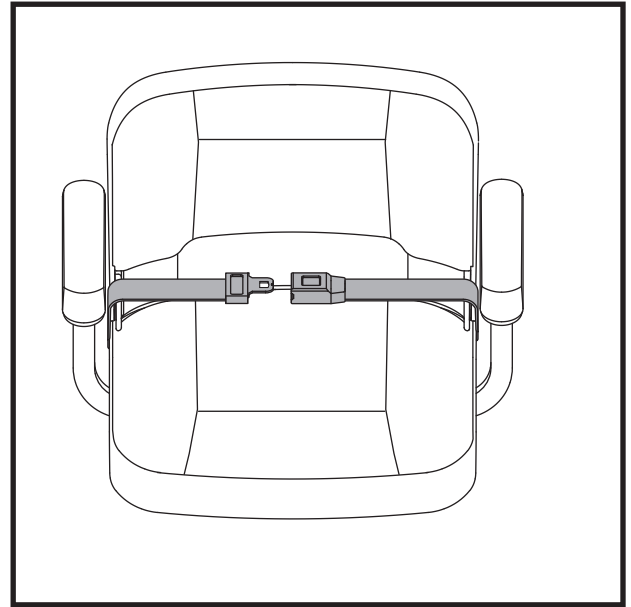

Figure 24. Positioning Belt - Metal Tab Style

MANDATORY! Make sure the positioning belt is properly secured to the scooter and is adjusted for operator comfort before each use.



MANDATORY! Inspect the positioning belt for loose parts or damage, including tears, worn spots, bent hardware, or damaged latch mechanisms, dirt or debris, before each use of the scooter. If you discover a problem, contact your authorized Provider for maintenance and repair.

VI. DISASSEMBLY AND ASSEMBLY

DISASSEMBLY

You can disassemble the scooter into several pieces: the seat, the rear section, the front section, the basket, the batteries, and the battery shroud. See **figure 25**. No tools are required to disassemble or assemble your scooter, but keep in mind that the disassembled sections of the scooter take up more floor space than the assembled unit. Always disassemble or assemble your scooter on a level, dry surface with sufficient room for you to work and move around your scooter—about 5 feet (1.5 meters) in all directions. Remember that some scooter components are heavy and you may need assistance when lifting them.



WARNING! Do not lift beyond your physical capability. Ask for assistance when necessary while disassembling or assembling your scooter.

WARNING! Do not pick up the seat frame or scooter by the armrests. They are free to pivot, and you may lose control of the seat if they do so.

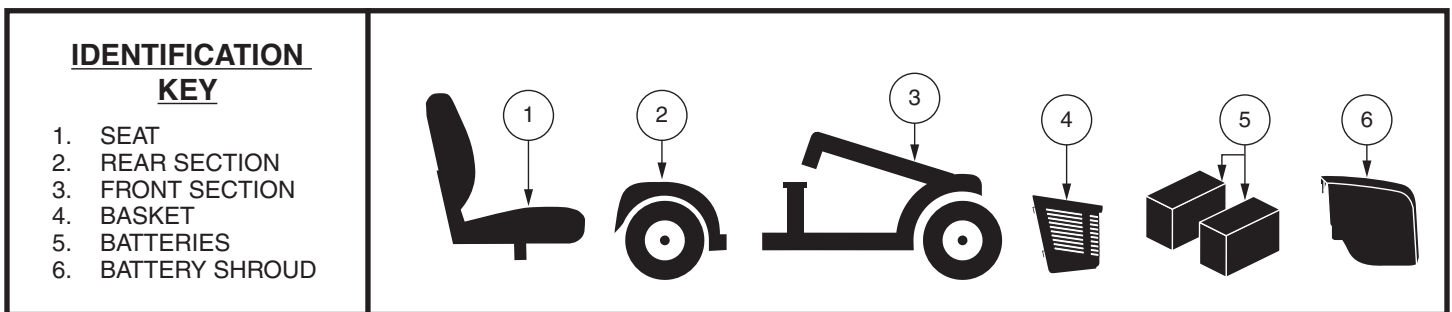

Figure 25. Disassembled Scooter

DISASSEMBLY PROCEDURES

1. Remove the key from the key switch. *For model 104*, lock the tiller in the straight ahead position by pushing the tiller lock knob in and turning it clockwise 90°. See **figure 26**. The front wheel must face forward in order to lock the tiller.
2. Remove the seat by lifting it straight up and off of the scooter. If you encounter resistance when removing the seat, disengage the seat rotation lever and swivel the seat back and forth while lifting up on the seat.
3. Gently pull the battery shroud forward, then lift up and off of the scooter. See **figure 13**.
4. Disconnect the battery tie-down strap. See **figure 14**.
5. Unplug both battery harnesses by depressing the tabs and then pulling each harness straight up. See **figure 14**.
6. Remove the batteries from the battery wells.



WARNING! Failure to unplug both battery harnesses prior to separating the front and rear sections could result in permanent damage to the scooter.

7. *For model 104 and 710ZT*, you may also need to disconnect both motor/front-to-rear harnesses. See **figure 14**.



WARNING! Failure to unplug both front-to-rear harnesses prior to separating the front and rear sections could result in permanent damage to the scooter.

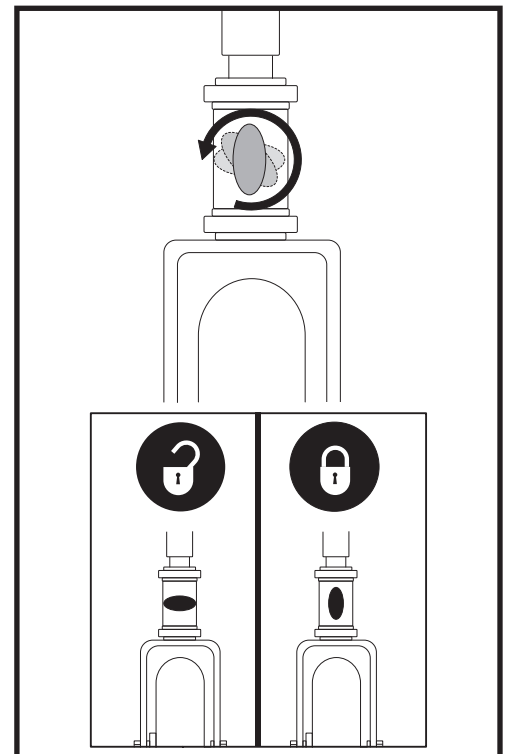

Figure 26. Tiller Lock Knob (Model 104 only)

NOTE: Please check the Scooter Features Table on the inside of the front cover to determine if your scooter has a frame release lever or a lockup pin before attempting to separate the frame.

VI. DISASSEMBLY AND ASSEMBLY

FRAME SEPARATION

1. Arrange the front wheel(s) in a straight forward-facing position.
2. With the seat and batteries removed (see Disassembly Procedures on previous page), lower the tiller and tighten the tiller adjustment knob. See **figure 18 or 26**.

NOTE: *The pivoting tiller is equipped with a mechanism that will lock the front wheels in place when the tiller is completely lowered and secured.*

3. Remove the frame lockup pin (*Model 104 only*) See **figure 27**.
4. Lift up on the frame release lever, (**OR, lift the seat post for model 104**) and pivot the rear section backwards, until the frame hooks are no longer resting on the lower frame tube.
5. Slowly separate the two sections.

ASSEMBLY

1. Position the front and rear sections of your scooter as shown in **figure 27**.
2. Use the frame release lever (or the seat post for model 104) to lift the front section as you align the frame hooks of the front section with the lower frame tube of the rear section. See **figure 27**.
3. Once the frame hooks are over the lower frame tube, lower the front section and pivot the rear section simultaneously. This will engage the frame lockup automatically for all models except 104. *For model 104*, you will also need to reinstall the frame lockup pin to complete the body assembly.
4. Raise the tiller and fully tighten the tiller adjustment knob.
5. Reinstall the batteries to the battery wells.
6. Properly connect all the battery harnesses. See **figure 14**.
7. Secure the battery tie-down strap. *For model 104 and 710ZT*, also reconnect both front-to-rear harnesses.
8. Reinstall the battery shroud.
9. Reinstall the seat and rotate it into place.



WARNING! After assembly, make absolutely certain the tiller lock knob is in the unlocked position before driving the scooter.

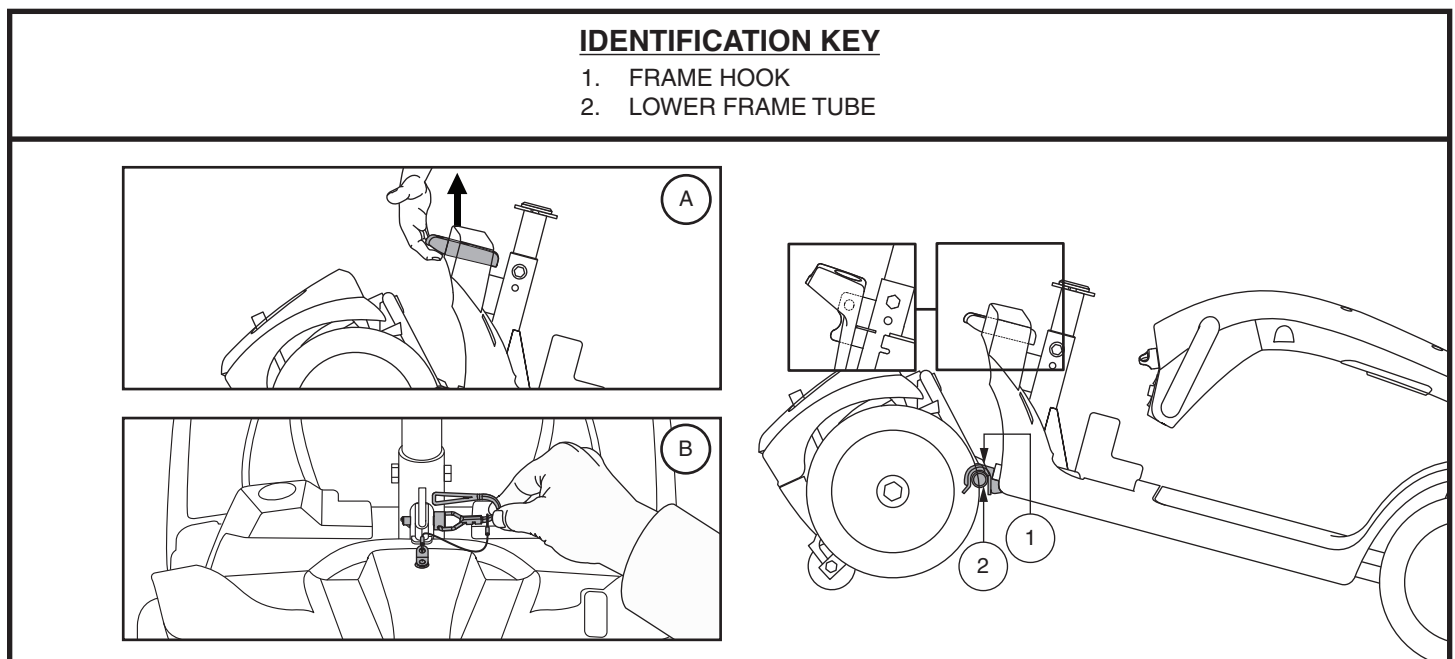

Figure 27. Frame Release Lever (Style A) and Frame Release Lockup Pin (Style B)

VII. BASIC TROUBLESHOOTING

Any electromechanical device occasionally requires some troubleshooting. However, most of the problems that may arise can usually be solved with a bit of thought and common sense. Many of these problems occur because the batteries are not fully charged or because the batteries are worn down and can no longer hold a charge.

DIAGNOSTIC CODES

The diagnostic codes for your Scooter are designed to help you perform basic troubleshooting quickly and easily. A diagnostic code will sound and/or flash in the event one of the conditions listed below develops. Depending on the model you own, your Scooter will communicate by one of the coding methods as follows:

1. A diagnostic code will begin, depending on model, with a series of fast beeps and/or flashes directly followed by slower beeps and/or flashes which indicates the actual code. The code is only beeped and/or blinked once. To repeat the diagnostic code, remove the key, then reinsert it and turn it to the “on” position, **OR**
2. A diagnostic code will identify the condition, pause, then repeat the code. The diagnostic code will continue to alert you in this manner until the scooter is turned off.

NOTE: Your scooter will not run unless the code condition is resolved and the scooter has been turned off, then turned back on.

BEEP CODE	CONDITION	SOLUTION
■ (1)	Battery charge is too low to operate the scooter.	Charge batteries as soon as possible.
■ ■ (2)	Battery charge is too low.	Charge batteries.
■ ■ ■ (3)	The scooter’s battery voltage is too high to operate the scooter, or the charger is still connected to the off-board charger port.	Unplug charger and/or turn key off, then back on again.
■ ■ ■ ■ (4)	Current limit time out.	Turn the scooter off for a few minutes, then turn your scooter back on.
■ ■ ■ ■ ■ (5)	The manual freewheel lever is in the freewheel position.	Remove the key from the key switch, then push the manual freewheel lever to the drive position and restart your scooter.
■ ■ ■ ■ ■ ■ (6)	Throttle control lever not at center position at start up.	Verify that the batteries are fully charged. If the batteries are fully charged, then return the throttle control lever to center position, turn scooter off then back on.
■ ■ ■ ■ ■ ■ ■ (7)	Speed pot error.	Contact your authorized Provider for assistance.
■ ■ ■ ■ ■ ■ ■ ■ (8)	Motor volts error.	Contact your authorized Provider for assistance.
■ ■ ■ ■ ■ ■ ■ ■ ■ (9)	Other internal errors.	Contact your authorized Provider for assistance.

Figure 28. Models with Tiller Console

VII. BASIC TROUBLESHOOTING

What if all the systems on my scooter seem to be dead?

- Make certain that the key is in the “on” position.
- Check that the batteries are fully charged.
- Push in the main circuit breaker reset button. See II. “Your Scooter.”
- Make certain that the battery and front-to-rear harnesses are connected properly.
- Be sure the power down timer feature has not been activated. See IV. “Operation.”

What if my scooter does not move when I engage the throttle control lever?

- When the manual freewheel lever is pushed forward, the brakes are disengaged and all power to the motor/transaxle assembly is cut.
- Push rearward on the manual freewheel lever, turn the scooter off, and then turn the scooter on to return to normal scooter operation.

What if the main circuit breaker repeatedly trips?

- If the main circuit breaker trips repeatedly, see your authorized Provider for service.
- Charge the batteries more frequently. See III. “Batteries and Charging.”
- If the problem continues, have both of your scooter’s batteries load tested by your authorized Provider.
- You may also perform the load test yourself. Battery load testers are available at most automotive parts stores. Follow the directions supplied with the load tester.
- See III. “Batteries and Charging” or “Product Specifications” insert for information about your scooter’s battery type.

What if the battery condition meter dips way down and the motor surges or hesitates when I engage the throttle control lever?

- Fully charge your scooter’s batteries. See III. “Batteries and Charging.”
- Have your authorized Provider load test each battery.
- See the previous troubleshooting question for load testing the batteries yourself.

If you experience any problems with your scooter that you are not able to solve, immediately contact your authorized Provider for information, maintenance and service.

VIII. CARE AND MAINTENANCE

Your scooter requires a minimal amount of care and maintenance. If you do not feel confident in your ability to perform the maintenance listed below, you may schedule inspection and maintenance at your authorized Provider. The following areas require periodic inspection and/or care and maintenance.

SOLID TIRE SAFETY CHECK

Regularly inspect your scooter's tires for signs of damage or wear.

WHEEL REPLACEMENT – SOLID TIRES

If your scooter is equipped with solid tire inserts and you have a damaged or worn tire, the entire wheel must be replaced. Contact your authorized Provider for information regarding replacement wheels for your scooter.



WARNING! Wheels on your scooter should only be serviced/replaced by a qualified technician.

WARNING! Be sure that the key is removed from the key switch and the scooter is not in freewheel mode before performing this procedure.

Follow these easy steps for a quick and safe repair for solid tires:

1. Remove the key from the key switch.
2. Elevate the side of the scooter of which you are removing the tire. Place wooden blocks under the frame to elevate the scooter.
3. Remove the wheel cap, drive wheel nut and washer from the axle. See figure 29.
4. Pull the wheel off of the axle.
5. Slide the new wheel onto the axle. Make sure the the axle key is in the axle slot.



WARNING! Ensure that the axle key is properly installed into the axle slot when mounting the wheel. If not installed securely, the braking system is disengaged which may cause personal injury and/or product damage may result.

6. Reinstall the washer and drive wheel nut onto the axle and tighten.



WARNING! Make sure that both the nut and washer are reinstalled and tightened properly.

7. Reinstall the wheel cap.
8. Remove the blocks from beneath the scooter.

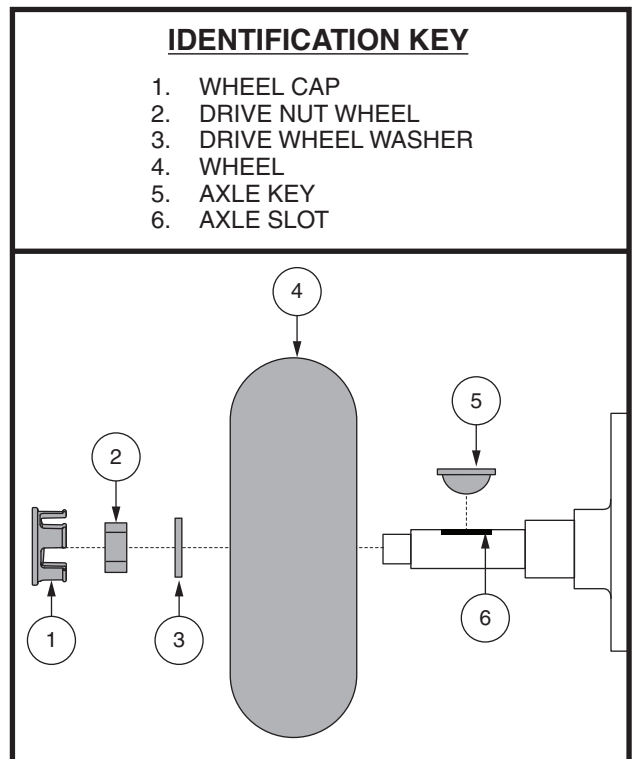

Figure 29. Wheel Removal

VIII. CARE AND MAINTENANCE

TIRE PRESSURE – PNEUMATIC TIRES

- If equipped with pneumatic tires, always maintain the psi/bar/kPa air pressure rating indicated on each tire.



WARNING! It is important that the psi/bar/kPa air pressure rating indicated on each tire be maintained in pneumatic tires at all times. Do not underinflate or overinflate your tires. Low pressure may result in loss of control and overinflated tires may burst. Failure to maintain the psi/bar/kPa air pressure rating indicated on the tires at all times may result in tire and/or wheel failure.

- Regularly inspect your scooter's tires for signs of damage or wear.

WHEEL REPLACEMENT – PNEUMATIC TIRES

If your scooter is equipped with pneumatic tires and you have a flat tire, you can have the tube replaced. Contact your authorized Provider for information regarding replacement wheels for your scooter.

WARNING! Wheels on your scooter should only be serviced/replaced by a qualified technician.



WARNING! Be sure that the key is removed from the key switch and the scooter is not in freewheel mode before performing this procedure.

WARNING! When changing a pneumatic tire, remove only the drive wheel nut and washer, then remove the entire wheel assembly. If any further disassembly is required, deflate the tire completely or it may explode.

Follow these easy steps for a quick and safe repair for pneumatic tires:

1. Remove the key from the key switch and ensure your scooter is not in freewheel mode.
2. Elevate the side of the scooter of which you are removing the tire. Place wooden blocks under the frame to elevate the scooter.
3. If you are replacing the tube, deflate the tire completely before taking it off the axle.
4. Remove the drive wheel nut and washer from the axle. **See figure 29.**
5. Remove the drive wheel from the axle.
6. Remove the lug nuts and washers and separate the rim halves. **See figure 30.**
7. Remove the old tube from the pneumatic tire and replace it with a new tube. **See figure 30.**
8. Reassemble the rim halves and tire by reconnecting the lug nuts and washers.
9. Slide the wheel back onto the axle. Make sure that the axle key is in the axle slot. **See figure 30.**



WARNING! Ensure that the axle key is properly installed into the axle slot when mounting the wheel. If not installed securely, the braking system is disengaged which may cause personal injury and/or product damage may result.

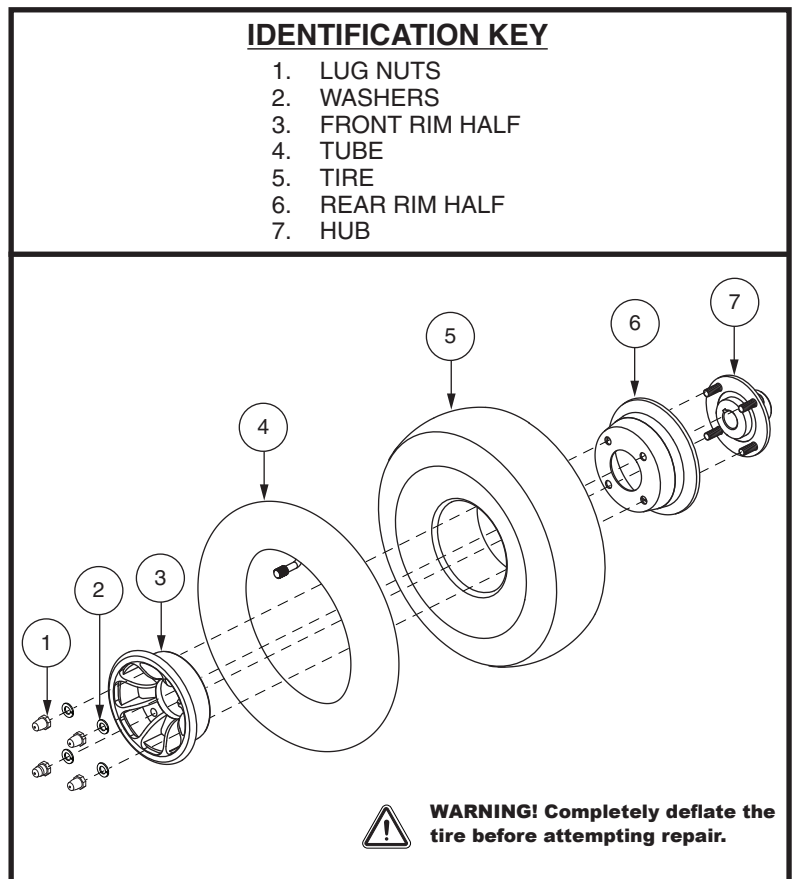

Figure 30. Pneumatic Drive Wheel Disassembly/Assembly

VIII. CARE AND MAINTENANCE

10. Reassemble the rim halves and tire by reconnecting the lug nuts and washers.



WARNING! Make sure that both the nuts and washers are reinstalled and tightened properly.

11. Inflate tires to the pressure in psi/bar/kPa indicated in each tire.

12. Remove the blocks from beneath the scooter.

EXTERIOR SURFACES

Bumpers, tires and trim can benefit from an occasional application of a rubber or vinyl conditioner.



WARNING! Do not use a rubber or vinyl conditioner on the scooter's vinyl seat or tire tread, as this may cause them to become dangerously slippery.

CLEANING AND DISINFECTION

- Use a damp cloth and mild, non-abrasive cleanser to clean the plastic and metal parts of your scooter. Avoid using products that may scratch the surface of your scooter.
- If necessary, clean your product with an approved disinfectant. Make sure the disinfectant is safe for use on your product before application.



WARNING! Follow all safety instructions for the proper use of the disinfectant and/or cleaning agent before applying it to your product. Failure to comply may result in skin irritation or premature deterioration of upholstery and/or scooter finishes.

BATTERY TERMINAL CONNECTIONS

- Make certain that the terminal connections remain tight and uncorroded.
- The batteries must sit flat in the battery wells.
- The battery terminals should face in the proper direction, according to the battery wiring diagram.

WIRING HARNESSSES

- Regularly check all wiring connections.
- Regularly check all wiring insulation, including the charger power cord, for wear or damage.
- Have your authorized Provider repair or replace any damaged connector, connection, or insulation that you find before using your scooter again.



PROHIBITED! Even though the scooter has passed the necessary testing requirements for ingress of liquids, you should keep electrical connections away from sources of dampness, including direct exposure to water or bodily fluids and incontinence. Check electrical components frequently for signs of corrosion and replace as necessary.



WARNING! Do not pull on electrical harnesses directly to detach them from the scooter. Always grasp the connector itself when disconnecting the harness to prevent wire damage.

DAILY CHECKS

- With the power turned off, check the throttle. Make sure it is not bent or damaged and that it returns to the neutral position when you release it. Do not try to repair it. See your authorized Provider if there is a problem.
- Visually inspect the tiller cable. Make sure that it is not frayed, cut, or has any wires exposed. See your authorized Provider if there is a problem.
- Check for flat spots on solid tires. Flat spots could adversely affect stability.
- Inspect the armrests for loose hardware, stress points, or damage. See your authorized Provider if there is a problem.
- Check the brakes. This test should be carried out on a level surface with at least 3 feet (1 meter) of clearance around your scooter.

VIII. CARE AND MAINTENANCE

To check the brakes:

1. Turn on the power and turn down the speed level of your scooter.
2. After one second, check the battery condition meter. Make sure that it remains on.
3. Slowly pull the throttle forward until you hear the electric brakes click. Immediately release the throttle. You must be able to hear the electrical brake operating within a few seconds of throttle movement. Repeat this test by pulling the throttle in the opposite direction.

WEEKLY CHECKS

- Inspect the controller and charger connectors for corrosion. Contact your authorized Provider if necessary.
- Check for proper tire inflation, if equipped with pneumatic tires. If a tire does not hold air, contact your authorized Provider for replacement of the tube.

MONTHLY CHECKS

- Check that the anti-tip wheels do not rub the ground when you operate the scooter.
- Check for extreme wear on the anti-tip wheels. Replace them as necessary.
- Check for tire wear. See your authorized Provider for repair.
- Keep you scooter clean and free of foriegn material, such as mud, dirt, hair, food, drink, etc.

YEARLY CHECKS

Take your scooter to your authorized Provider for yearly maintenance, especially if you use your Scooter on a daily basis. This helps ensure that your scooter is functioning properly and helps prevent future complications.

ABS PLASTIC SHROUDS

If your Scooter has a body shroud with a **glossy finish**, the body shroud has been sprayed with a clear sealant coating. You can apply a light coat of car wax to help it retain its high-gloss appearance. If your scooter has a body shroud with a **matte finish**, use **ONLY** products developed for matte-finish paint. Do not use wax, detail spray, ArmorAll®, or any product made for glossy paint.



WARNING! Carefully choose the correct product to protect the finish of your Scooter's shroud(s). ONLY products developed for matte-finish paint should be used on shrouds with a matte finish. Failure to follow this warning may result in damage to the shroud's matte paint finish.

AXLE BEARINGS AND THE MOTOR/TRANSAXLE ASSEMBLY

These items are all prelubricated, sealed, and require no subsequent lubrication.

MOTOR BRUSHES

The motor brushes are housed inside of the motor transaxle/assembly. They should be inspected periodically for wear by your authorized Provider.

CONSOLE, CHARGER AND REAR ELECTRONICS

- Keep these areas free of moisture.
- Allow these areas to dry thoroughly if they have been exposed to moisture before operating your scooter again.

VIII. CARE AND MAINTENANCE

FUSE REPLACEMENT

In the event a fuse should cease to work:

1. Remove the fuse by pulling it out of its slot.
2. Examine the fuse to be sure it is blown. See **figure 31**.
3. Insert a new fuse of the same rating.



WARNING! The replacement fuse must exactly match the rating of the fuse being replaced. Failure to use properly rated fuses may cause damage to the electrical system.

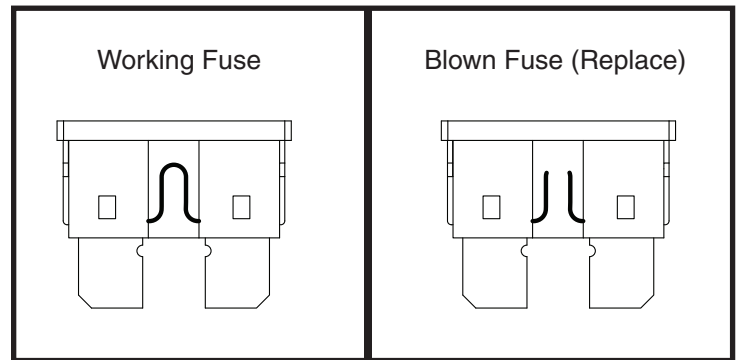

Figure 31. Fuse Replacement

NYLON LOCK NUT REPLACEMENT

Any nylon insert lock nut removed during the periodic maintenance, assembly or disassembly of the scooter must be replaced with a new nut. Nylon insert lock nuts should not be reused as it may cause damage to the nylon insert, resulting in a less secure fit. Replacement nylon insert lock nuts are available at local hardware stores or through your authorized Provider.

STORING YOUR SCOOTER

If you plan on not using your scooter for an extended period of time, it is best to:

- Fully charge its batteries prior to storage.
- Disconnect the batteries from the scooter.
- Store your scooter in a warm, dry environment.
- Avoid storing your scooter where it will be exposed to temperature extremes.
- Recommended storage temperature: -40°F/-40°C to 149°F/65°C.



WARNING! Always protect batteries from freezing temperatures and never charge a frozen battery. Charging a frozen battery can result in damage to the battery.

Batteries that are regularly and deeply discharged, infrequently charged, stored in extreme temperatures or stored without a full charge may be permanently damaged, causing unreliable performance and limited service life. It is recommended that you charge the scooter batteries periodically throughout periods of prolonged storage to ensure proper performance.

You may wish to place several boards under the frame of your scooter to raise it off of the ground during periods of prolonged storage. This takes the weight off the tires and reduces the possibility of flat spots developing on the areas of the tires contacting the ground.

DISPOSAL OF YOUR SCOOTER

Your scooter must be disposed of according to applicable local and national statutory regulations. Contact your local waste disposal agency or authorized Provider for information on proper disposal of packaging, metal frame components, plastic components, electronics, batteries, neoprene, silicone and polyurethane materials.



WARNING! ! Plastic bags are a suffocation hazard. Dispose of plastic bags properly and do not allow children to play with them.