



eFOLDi®



# eFOLDi User Manual

Model: Power Chair HBLD3-D



SunTech UK Ltd

**Purchased from:**

---

---

---

**Date of purchase:**

---

**Serial number:**

---

**Please see image showing the location of the serial number.**



## Contents

<b>1</b>	<b>Welcome</b>	<b>2</b>
<b>2</b>	<b>Terms, conditions and disclaimers</b>	<b>3</b>
<b>3</b>	<b>Product overview</b>	<b>6</b>
<b>4</b>	<b>Components</b>	<b>7</b>
<b>5</b>	<b>Safety guidance</b>	<b>9</b>
<b>6</b>	<b>Folding instructions</b>	<b>13</b>
<b>7</b>	<b>Drive your power chair</b>	<b>17</b>
<b>8</b>	<b>Battery and Charging</b>	<b>21</b>
<b>9</b>	<b>Checks and maintenance</b>	<b>25</b>
<b>10</b>	<b>Technical specification</b>	<b>26</b>
<b>11</b>	<b>Appendix</b>	<b>27</b>

## Welcome

Thank you for choosing an eFOLDi product as your mobility solution.

I'm Sumi Wang, the founder of SunTech UK and would like to welcome you to the eFOLDi family of users.

SunTech UK manufactures a range of assistive technologies to help you get the most from life. Our mission is to give our customers freedom, friendship and fun with a range of easy to use, convenient and market leading mobility solutions.

Your eFOLDi has been manufactured to the highest standards and quality checked by our own pre-sales technicians before delivery, to provide you with a product that will give many years of freedom and fun with reliable service.

Please take some time to read the user manual and the supplied documents before using your eFOLDi for the first time, this will help you understand the product and help you obtain maximum enjoyment and safety from your new eFOLDi product(s). You will quickly become familiar with the features of your eFOLDi with a little practice.

SunTech UK prides itself on its high-quality products and customer support so please remember to register your product(s) at: <https://efoldi.com/register-warranty>

These will help us to assist you in the event of any difficulties you may experience in the future. I am sure you will find your eFOLDi to be a reliable friend and companion and I thank you for your custom and your trust in our products.

Yours,



Sumi Wang

---

## Terms, conditions and disclaimers

The terms 'us', 'we', 'our', 'SunTech UK' and 'SunTech UK Ltd' mean SunTech UK Limited, which is a UK registered company, limited by guarantee, registered with Companies House, number 06906908. The terms 'website' means the website found online at [www.efoldi.com](http://www.efoldi.com). The terms 'you', 'your', 'user' and 'rider', mean the person using the eFOLDi not withstanding any person(s) handling the eFOLDi on behalf of the user, if different to the user, including general handling, maintenance, repairs and so on.

## Purchase agreement

By accepting delivery of this eFOLDi, you undertake to not change, alter or modify this eFOLDi and/or any parts supplied with it or subsequently for it, and/or render inoperable or unsafe, any guards, shields or other safety features of this product; fail, refuse or neglect to install any retrofit kits from time to time, as may be provided by SunTech UK Ltd to enhance and/or preserve the safe use of this product . You also agree to accept and abide, by/with the terms and conditions contained herein and as may be revised from time to time and updated on our website, being immediately applicable. By using the eFOLDi and/or accessories and/or components supplied with/or for the eFOLDi, the user acknowledges having read and understood the use(s) and limitations of the product(s) without exceptions. This shall not act as a waiver of any implied warranties, which customer retains, as provided by law.

Warranties will be void and SunTech UK Ltd will accept no responsibility whatsoever or howsoever, in instances of misuse and/or abuse of the products, in part or in full, by the user and/or any unauthorised persons, which may include (but not to be limited to); the user(s) failing to comply with all legal requirements and guidelines, wherever and/or however it is used or intended to be used, lack of/or inappropriate maintenance, maintenance (apart from the routine maintenance as described in this manual by the user) by anyone not approved to do so, unapproved repairs, unauthorised disassembly of the vehicle and/or components includ-

ing (but not limited to) battery pack(s) and controllers, unapproved modifications or alterations, failure to ensure correct folding and unfolding procedures are followed precisely and in full, damage or injury howsoever caused, failure to apply all reasonable and appropriate safety precautions at all times, improper use of the vehicle and/or parts and/or accessories being used by more than one person at any times, use in any competitive sport, racing, stunts, jumping or other similar activity.

Our liability and the liability of our suppliers, to you/or any third parties in any circumstances is limited to the user's cost of qualifying products purchased. Qualifying products as acceptable for the return, as outlined in the return policy, as stated on the website online at: [www.efoldi.com/return-policy](http://www.efoldi.com/return-policy).

Information in this user manual is subject to change without prior notice. For the latest updates and information, please go to our website online at: [www.efoldi.com](http://www.efoldi.com).



## **The power chair should NOT be used by people:**

- With a mental impairment which requires on going supervision or assistance;
- With slow reaction and who have difficulty in handling power mobility devices;
- Who cannot operate all controls fully and as intended; \*
- Who cannot steer competently and appropriately at all times and in all conditions;
- Who cannot maintain appropriate awareness of all relevant circumstances for each journey and take appropriate action as may be required to avoid mishap;
- Who cannot lift it in whole or in part as may be required dependent upon user's needs\*.

\* Unless accompanied by a person sufficiently able and competent to carry out that task.

## **Product compliance:**

<b>Safety:</b>	<b>EN12184</b>
<b>EMC:</b>	<b>ISO7176-21</b>
<b>Risk management:</b>	<b>ISO14971</b>
<b>The European Medical Devices: Class 1</b>	<b>Directive of 93/42/EEC</b>

## **Shipping and delivery:**

By checking against your sales order or invoice, make sure your delivery is complete, as some components may be individually packaged. If you do not receive a complete delivery, please contact us immediately. Where damage has occurred during transport, either to the packaging or the content, please contact the delivery company responsible.

## Product overview

Thank you for purchasing our eFOLDi power chair. This ultra-light electric wheelchair has been carefully researched and developed to be light, energy efficient and easy to operate. Please read this manual carefully before use, so that you are familiar with all the various functions, and understand the required maintenance. This will ensure that the power chair remains in good condition and is safe to use.



(a) Power chair mode



(b) Storage mode

**Model: Power chair HBLD3-D**



## Components

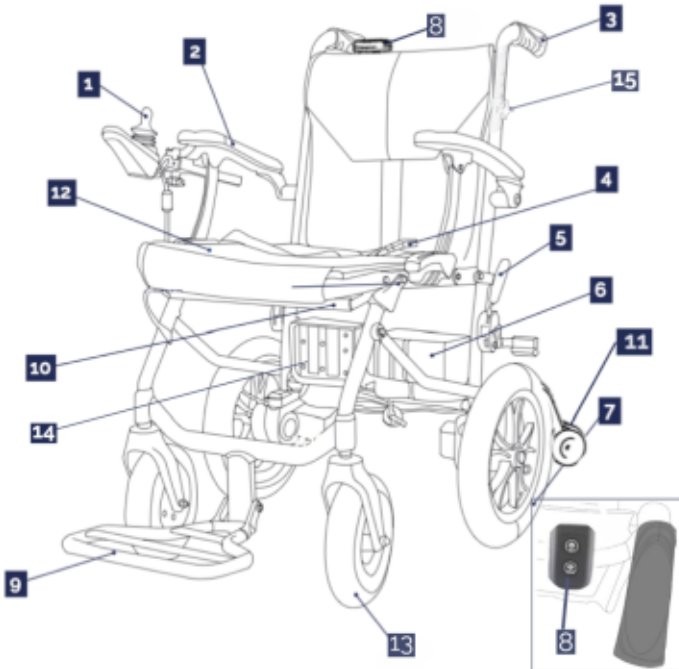

1	Joystick control	2	Armrest
3	Push handle	4	Seatbelt
5	Handbrakes (both sides)	6	Batteries
7	Rear wheel 12 inch	8	Attendant control
9	Footrest	10	Folding mechanism bar
11	Anti-tip wheels	12	Seat cover
13	Front wheel	14	Control box
15	Push bar height adjustment knob		

Table 1: Model HBLD3-D Components

## Control components

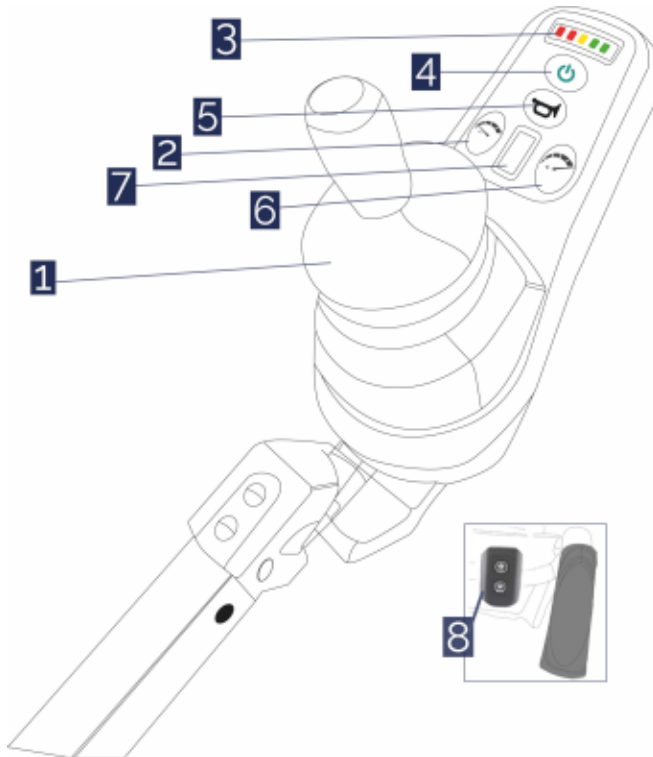

1	Joystick control	2	Speed adjustment (slower)
3	Battery power display	4	Power switch
5	Horn	6	Speed adjustment (faster)
7	Speed indicator	8	Attendant control

Table 2: Power chair HBLD3-D controls

## Safety guidance



### Attention

- It is the user's responsibility to read the manual and supplied documents before using the eFOLDi and to follow all of the recommendations contained within, to fully comply with all local laws of their countries and localities and to use the eFOLDi with due diligence and regard to other road users and pedestrians.
- The eFOLDi is simple to use, but its folding mechanism can cause significant injury if used inappropriately and handled without due care and diligence. To avoid any risk of injury ensure hands, fingers, jewellery, clothing and other objects are not allowed to interfere with the folding mechanism or moving parts of the eFOLDi and study the manual carefully before you start operating your eFOLDi.
- It is advised that the user familiarise themselves with the folding and unfolding procedure before venturing outside. The user should also ensure that they familiarise themselves with the controls and handling of the power chair in a safe area away from obstacles and other pedestrians or road users.
- Fully charge the battery(ies) before first use and follow the guidelines in this manual for prolonging the life of your battery.

### Caution:

Do NOT ride over rough, cobbled, muddy or loose gravel surfaces. Your eFOLDi is designed for smooth and firm footpaths, roads and pedestrian areas only.

The stopping distance on slopes can be significantly greater than on level ground; The power chair surface temperatures can increase when exposed to external sources of heat (e.g. sunlight)



**Cannot be driven on the road.**

**Be sure to slow down before turning. Do not make sharp turns at high speed. Do not park the eFOLDi power chair on a ramp. Never make turns on a slope.**

**Do not ride over rough, cobbled, muddy or loose gravel surfaces. Your eFOLDi power chair is designed for smooth and firm foot-paths and pedestrian areas only.**

**Any vehicle can be dangerous to its rider/driver and other road users and pedestrians. Always ride/drive responsibly, respectfully and with due care to others.**

**Your eFOLDi power chair is NOT a toy and is not recommended for people under the age of 14. Do not allow children to play with or on the power chair. The internal folding mechanism can cause injury to small hands.**

**Do not operate your eFOLDi power chair until you have read and fully understood this manual.**

**Do not operate your eFOLDi power chair until assembly and inspection is complete. It is suggested that people with mental abnormality, slow reactions and difficulty in handling powered devices should not use the eFOLDi power chair on their own.**

**Do not get on or off the eFOLDi power chair when the power is on, or when the power chair is in freewheel mode or with the hand-brakes disengaged, or there is no carer to provide assistance.**

**Do not drive your eFOLDi power chair in violation of national and local traffic regulations.**

**Do NOT rush when folding or unfolding the eFOLDi power chair.**

**Do not use the eFOLDi power chair on sandy or soft ground. Avoid driving on slopes greater than 6 degrees or over obstacles greater than 4 cm in height.**

**Do NOT disassemble or change parts of the eFOLDi power chair or replace parts not manufactured by the manufacturer without the manufacturer's permission.**

**Never operate the power chair without the anti-tip wheels se-**

curely in place.

Do NOT for any reason put your hands into the mainframe of the power chair. This is because your hands and fingers can get trapped in the levers and pivots and serious injuries can be caused.



### **When unfolding/folding your power chair ensure:**

- The eFOLDi is positioned on a level floor or ground.
- Main switch is switched off.
- All latch pins are properly secured in place, as stated on the instructions and shown on the illustrations.
- Handbrake is disengaged.



### **Safety check before use:**

It is highly recommended that you perform a safety check before each use to make sure your eFOLDi operates smoothly and safely.

- Check for correct tyre inflation. Maintain but do not exceed the manufacturer recommended tyre pressure rating indicated on the pneumatic tyres;
- Check all electrical connections. Make sure they are secure and not corroded;
- Check and test the brake system;
- Check frequently for any loose fasteners, fixings and other components.
- Check Anti-tip wheels are securely attached.



## **EMC warning statement**

The interference from radio wave sources such as radio stations, TV stations, two way radios or cellular phones can cause the mobility product to release its brakes, move by itself, or move in unintended directions. It can also permanently damage the mobility power chair control system.

The intensity of the interfering EM energy can be measured in volts per meter (V/m). Each mobility product can resist EMI up to a certain intensity. This is called the "EMI immunity level". The higher the EMI immunity level, the greater the protection from EMI. Currently the eFOLDi power chair has an immunity level of at least 20V/m, which provides useful protection from the common sources of EMI.

The sources of radiated EMI can be broadly classified into three types: 1) Hand-held portable transceivers. (normally with antenna mounted on the device) 2) Medium-range mobile transceivers, such as those used in police cars, fire trucks, ambulances and taxis. (normally with antenna mounted on the vehicle) 3) Long-range transmitters and transceivers, such as commercial broadcast transmitters (radio and TV broadcast antenna towers) and amateur (HAM) radios.

Other types of hand-held devices, such as cordless phones, laptop computers, AM/FM radios, TV sets and small appliances such as electric shavers and hair dryers are usually not likely to cause EMI problems.

## Folding instructions

### To a Power chair mode



Please study the instruction and image illumination to familiarise the folding procedures and please only operate one moving part at the same time.

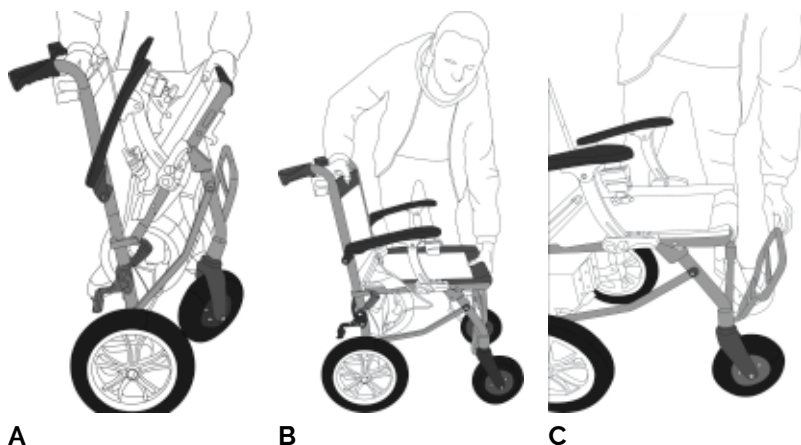

**A** Once removed from the packaging place the wheelchair on a stable surface. Place one hand on the top of the backrest and the other hand on the folding mechanism bar underneath the seat, in the front part of the folded power chair.

**B** Finally push your two hands apart until the seat is open at 90° degrees and you hear a distinct "click" sound.

**C** Unfold the footrest, from a vertical position to a 90° degrees horizontal position.



D

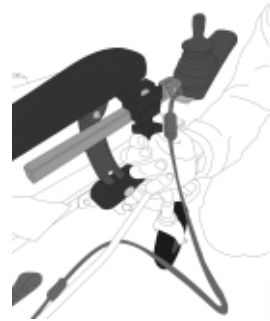

E

**D** Slot the joystick arm inside the frame and push it, into a comfortable horizontal position, where it is easy for your hand to reach the joystick.

**E** Once you are happy with the horizontal position of the joystick arm, lock it by tightening the clamp. Finally attach Anti-tip wheels securely on the back of the power chair before driving off.



**Power chair mode**



## To a Storage mode



Please study the instruction and image illumination to familiarise the folding procedures and please only operate one moving part at the same time.

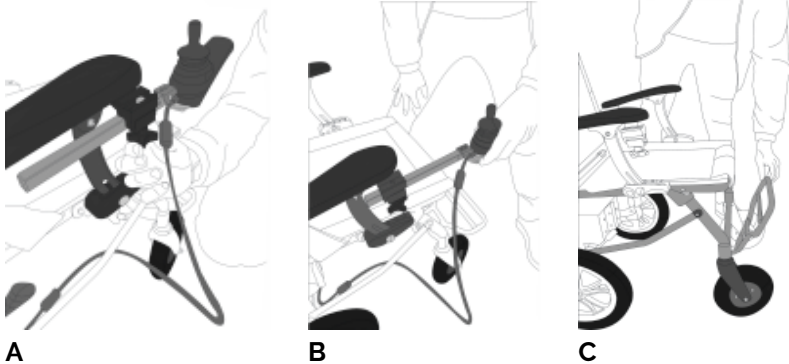

**A** Loosen the tightening clamp, to release the joystick arm.

**B** Take out the joystick arm and place it on the power chair seat.

**C** Fold the footrest, at 90° degrees position vertically.



E



F

**E** Then place one hand at the top on the backrest bar and the other on the folding mechanism bar underneath the seat.

**F** By pressing the folding mechanism bar and bringing your hand together to close and fold the eFOLDi Power chair. Your power chair is ready to be stored or transported.

**Front wheel should face backwards for proper folding.**



**Storage mode**

## Drive your power chair



### **Safety check before use - see Safety Guidance**

eFOLDi power chair is suitable to use indoor or drive on the pavement only and is designed to drive on smooth even surfaces. When driving your eFOLDi, choose a route with good road conditions. Unevenly paved roads or paths, potholes and other hazards, will reduce the life of the power chair and impact on your safety.

Any deviation from level/horizontal surfaces should not exceed a gradient of 1:10 (6 degrees). For any climbing there are many factors that need to be considered. Such as: the tyre pressure and condition, the surface condition (if wet, icy or slippery, and this includes leaf cover and/or other debris, we advise against driving the slope), batteries charge and the weight of the user, all of these will affect performance.

### **Caution:**

The stopping distance on slopes can be significantly greater than on level ground; The power chair surface temperatures can increase when exposed to external sources of heat (e.g. sunlight)

## Joystick and Controlbox

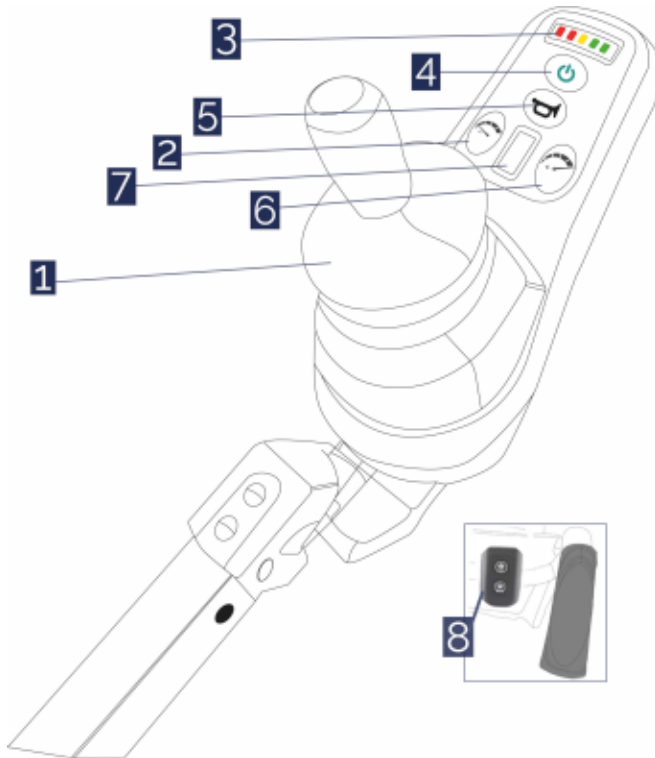

Main Power switch

 **Perform the safety check before each use**  
**- see Safety Guidance section.**

## Operate the power chair

- To Start - Switch on the main power switch and press the power button on the joystick to switch on the power chair.
- To Stop - Switch off the power button on the joystick and apply manual brakes, which are located on both sides of the chair. When parking on a ramp/slope, the electromagnetic brake may not always be strong enough. Always use the manual brake in conjunction with the electromagnetic brake.
- Adjust the speed - Use speed adjustment button to reduce/increase the speed.
- Drive forward - Push the Joystick controller stick forward.
- Turn left/right - Push the Joystick controller stick left/right.
- Drive backward - Push the Joystick controller stick backward.
- Use attendant control - Push Go button to go forward; Push Back button to go backward. **When Attendant Control is in use, the chair no longer responds to the Joystick controller.**
- Joystick controller (1) controls the direction and speed at the same time, slowly push the joystick towards the driving direction, then the eFOLDi Power chair will start to move, push the joystick further and you will notice greater acceleration.
- Speed adjustment - slower (2) It is positioned just above the control handle on the left hand side, and it decreases the speed to make the eFOLDi power chair easier to control.

- Power display (3) Shows the battery charge remaining.
- Power button (4) Switches the power on and off by pressing the button(Make sure the main power switch is on).
- Horn (5)Horn: Positioned right in the middle of the control panel, use this to warn other pedestrians, of your presence.
- Speed adjustment - faster (6) It is positioned just above the control handle on the right hand side, and by pressing the button it increases the speed level of the power chair to go faster. Always be aware of your speed.
- Speed display (7) Indicates what speed is currently selected.
- Attendant control (8) Allows an assistant to power the chair for easy handling.
- Freewheel/motor bypass mode: Switch off the main power switch from the control box at the back of the power chair. It will give you freewheel/motor bypass mode, which you will still feel some resistance. **Do not use the power chair on a ramp/slope if the battery is out of power without applying manual brakes, it does not have any electromagnetic brake without power**



**Manual brakes**

## Battery and Charging



The eFOLDi power chair battery has been designed and built specifically for the eFOLDi power chair. This battery must not be used for any purpose other than as stated in this manual. Any misuse or dismantling of this battery may damage it physically and/or electrically, internally and/or externally and will not be covered by warranty. The battery contains no user serviceable or replaceable components. The eFOLDi power chair battery is actually a battery pack, comprising a number of lithium/ ion cells, but merely termed 'battery' for ease throughout this manual. This battery is different in characteristics and charging requirements to the old and still quite common lead/acid or lead/gel type. Never use a lead type charger to charge it.

To ensure best long-term use of the battery, please observe the following safety rules at all times.

- Connection dock must be handled with care to avoid damage.
- Charge the battery ONLY with the approved charger.
- Never use a charger for lead type batteries on the eFOLDi battery.
- Never place the battery near, on or against any heat source.
- Ensure no metal parts can touch (or 'short') battery or charger terminals, connectors, pins or any other electrical conductor(s) or conducting parts.
- Avoid excessive physical impact and vibration of the battery.

- Do not attempt to dismantle, dissect or deform the battery(ies) or case(s).
- Do not immerse the battery in any liquid (including water).
- Do not mix different types of batteries.
- Keep the battery out of reach of children.
- Do not use modified or damaged chargers.
- Do not leave the battery on charge for more than 24 hours.
- Store the battery in a cool, dry, well ventilated area.
- Dispose of the battery only in accordance with local laws and regulations.
- Batteries should not be stored for long periods without charging. It is recommended the battery to be charged monthly to prolong its life.
- Never store the battery when it is significantly discharged.

## Battery power display

Switch on the power, the power display light in the front row will be on, full power will show 5 lights (2 red, 1 yellow, 2 green). When the two red lights are flashing, this indicates that the battery requires charging.





To remove the battery for charging, push the red button down, hold the battery on the outside, and release from the Power chair. To put it back, slide the battery into the battery guide slot, push it until you hear a click, then the battery is inserted securely.

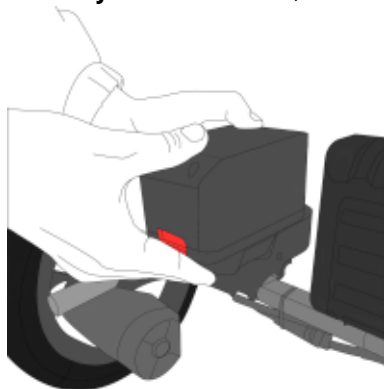

## Caution:

Please remove the battery and charge it once a month if not in use (Power chair batteries ideally should not be stored in the power chair).

## Charger and Charging

Use only the charger originally supplied with your new eFOLDi power chair or replacement charger supplied by SunTech UK Ltd for the use with your product. The use of a non-approved charger will invalidate any warranty and may cause serious damage to the battery and/or your eFOLDi product. The charger should not be used with/or for other devices as damage caused to the charger and/or any other device by doing so will not be covered by our warranty.

It is highly recommended to ensure the charger is placed only on heat resistant surfaces and nothing which could contribute to a fire (e.g. carpet, floorboards, wood, laminate or plastic worktops

etc)- the charger will heat up during a normal charging cycle, as will the battery.

Do not leave the battery on charge for more than 24 hours, as this will reduce the life and performance of the battery.

For the benefit of international travellers, your approved eFOLDi charger can be used with any mains voltage supply from 100 to 240 Volts, with a suitable travel adaptor.

See the image below. Insert the charger into the charging port to start charging.



For some models you can charge the battery without removing it from the bay on the back of the control box using the eFOLDi charger with a charging adaptor provided. **Do NOT use any other cable than 24VDC eFOLDi power chair charger to charge**



## Checks and maintenance



- Perform the following inspections prior to using your eFOLDi daily:

For pneumatic tyres, make sure you check the correct tyre inflation and maintain without exceeding the P.S.I./BAR/kPa air pressure rating indicated on each pneumatic tyre (note: the front and rear tyres may have different pressures). Also be sure to use the correct pressure scale and according number on your inflater/pressure tester.

- Perform the following inspections weekly:

Check the fastening condition of each nuts, bolts and screws to make sure all the parts are properly secured and are not missing or loose. Check all electrical connections. Make sure they are tight and not corroded. Electromagnetic brake - is used as a driving brake. The braking distance should be less than 1.5 metres after you release the joystick to stop. Tyre pressure - See your tyres for this information.

- Cleaning and maintenance

Periodic cleaning of your eFOLDi will help to maintain its appearance and will both extend the life of the vehicle and improve resale value. Metal and plastic parts can be wiped with a damp cloth using a mild detergent.

Have your eFOLDi regularly serviced each year.

### **Caution:**

Oil and other lubricants must NOT be used on the following parts: Brake pads, brake cable, tyres.

## Technical specification



<b>Frame material:</b>	<b>Aluminium Alloy</b>
<b>Dimension</b>	
<b>Packaging size (L/W/H):</b>	<b>37x60x94cm (15x24x37inch)</b>
<b>Folded size (L/W/H):</b>	<b>34x58x92cm (13x23x36inch)</b>
<b>Unfolded size (L/W/H):</b>	<b>96x58x92cm (38x23x36inch)</b>
<b>Front wheel size:</b>	<b>20cm (8inch)</b>
<b>Rear wheel size:</b>	<b>30cm (12inch)</b>
<b>Seat height:</b>	<b>48cm (19inch)</b>
<b>Weight</b>	
<b>Weight with battery:</b>	<b>17kg(38lbs)</b>
<b>Weight without battery:</b>	<b>15kg(33lbs)</b>
<b>Performance</b>	
<b>Place to use:</b>	<b>Pavement and indoor</b>
<b>Speed:</b>	<b>4mph(6kmh)</b>
<b>Maximum range capacity:</b>	<b>8miles (13km)</b>
<b>Maximum carry capacity:</b>	<b>135kg (297lbs/21stone)</b>
<b>Maximum Incline:</b>	<b>1:10 Gradient (6 degrees)</b>
<b>Turning radius left/right:</b>	<b>102 (40inch)</b>
<b>Maximum kerb height:</b>	<b>4cm (1.5inch)</b>
<b>Components capability</b>	
<b>Motor:</b>	<b>2 x 200W, 24VDC</b>
<b>Battery:</b>	<b>2 x 5.2Ah 24VDC Lithium Ion</b>
<b>Charger:</b>	<b>Input 110-220VAC, 50/60Hz, output 29.4V 2A</b>
<b>Brake:</b>	<b>Electric magnetic</b>
<b>Power switch:</b>	<b>Power button on joystick</b>
<b>Number of Wheels:</b>	<b>4</b>
<b>Tyre type:</b>	<b>Solid or pneumatic</b>

**Table 3: Specification-Power chair-HBLD3-D**

## Appendix



**SunTech UK Ltd**

**25 Ormside Way, Holmethrope Industrial Estate, Redhill, Surrey, RH1 2LW**



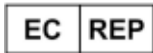







**TEL: +44 (0) 2031435168**



**MedPath GmbH**

**Mies-van-der-Rohe-Strasse 8, 80807 Munich, Germany**

### Symbols used on the label

	European CE Marking		Manufacturer
	Authorized representative in the European community		Medical device
	Serial number		Unique Device Identification
	Date of manufacture		Refer to instructions manual
	No trash bin		UK Conformity Assessed



(eFOLDi accessories)  
[www.efoldi.com/shop](http://www.efoldi.com/shop)



SunTech UK Ltd  
25 Ormside Way, Redhill,  
Surrey, RH1 2LW, UK



MedPath GmbH  
Mies-van-der-Rohe-Strasse 8  
80807 Munich, Germany



Official website address: [www.efoldi.com](http://www.efoldi.com)  
Service email: [services@efoldi.com](mailto:services@efoldi.com)  
Facebook: [www.facebook.com/efoldi.co.uk](http://www.facebook.com/efoldi.co.uk)