



Alumina

User Manual

Contents

1.	INSTRUCTIONS FOR USE	1
2.	INTRODUCTION	2
3.	GENERAL SAFETY INFORMATION	3
4.	GETTING TO KNOW YOUR SCOOTER	12
5.	PRODUCT SPECIFICATIONS	14
6.	PUSHING AND TRANSPORTING THE SCOOTER	15
6.1	PARTS	16
6.2	DISASSEMBLY	18
6.3	ASSEMBLY	19
7.	ADJUSTING THE SCOOTER	21
7.1	SWIVELING THE SEAT TO GET ON AND OFF	21
7.2	ADJUSTING THE TILLER ANGLE	21
7.3	TURNING THE SEAT	22
8.	OPERATING THE SCOOTER	24
8.1	POWERING ON/OFF	25
8.2	ADJUSTING THE SPEED	25
8.3	DRIVING FORWARDS AND BACKWARDS	26
8.4	OVERLOAD PROTECTION	27
8.5	SWITCHING ON THE HORN	27
8.6	DRIVING ON AN INCLINE	31
9.	BATTERY AND CHARGING	29
9.1	BATTERY STATUS DISPLAY	30
9.2	CHARGING THE BATTERIES	31
9.3	AFTER CHARGING	34
9.4	ERROR CODE	34
10.	EMI	36

BEFORE DRIVING

1. INSTRUCTIONS FOR USE

The scooter is a motorised electric scooter for use outdoors primarily on flat surfaces such as pavements, roads, parking lots and drive ways.

It is intended to increase the mobility of people who are both physically and mentally capable of correctly assessing driving situations and reacting accordingly to them at any time.

Uses:

DO NOT operate this equipment without first reading and understanding the user manual. If you are unable to understand the warnings, cautions, and instructions, please contact your dealer; otherwise injury or damage may result. Procedures other than those described in this manual **MUST** be performed by a qualified technician.

We reserve the right to make changes and update this manual without further notice.

2. INTRODUCTION

DEAR CUSTOMER

With your **Alumina** scooter, you have now purchased a product which has been manufactured in accordance with the latest technical capabilities and based on the highest levels of user comfort. We have placed great focus on the simplest possible operation and long service life in both construction and material selection.

This Operating Manual assumes that the suitability of the user for scooter usage has been discussed with a doctor, therapist and/or approved dealer before operation. The operating manual will help you get to know the function of your scooter and, in addition, describes

- Operation
- Care and maintenance
- Repair

This manual has been drawn up using information available at the time of printing with regard to construction and operation of the scooter. We reserve the right to make changes due to technical improvements.

If you have any other questions about this Scooter please contact the company you purchased it from.

GENERAL SAFETY INFORMATION

3. GENERAL SAFETY INFORMATION

Before you operate your scooter, please read and understand all of the information provided with your scooter for your safety. As operating any vehicle, only drive with full alertness to ensure safety.

Please observe the warnings below to avoid any damage or injury resulting from improper use of your scooter. The scooter user is responsible for taking proper safety measures. We will not be held liable for personal injury and/ or product damage resulting from improper use of the scooter.

- Obey all local pedestrian traffic rules. It may be difficult for others to see you when you are seated on your scooter. Wait until your path is clear of traffic, and then proceed with extreme caution. Use of safety equipment such as reflectors/reflective clothing, lights, and safety flags is advisory.
- Please consult your healthcare professionals routinely to ensure there are no health or physical conditions that may limit or impair your ability to safely operate your scooter.
- Consult your physician if you are taking prescription or over-the-counter medications or if you have any physical limitations. Some medications and physical limitations may impair your ability to safely operate your scooter.
- Do not operate your scooter while you are under the influence of alcohol, as this may impair your ability to safely operate your scooter.
- Every scooter is different. Take time to learn the feel of this scooter before driving.
- Anti-tippers substantially reduce your risk of tipping over backwards, which can cause serious injury.
- Have someone help you practice bending and

GENERAL SAFETY INFORMATION

reaching on the scooter and transferring to and from the scooter until you learn how to do it safely.

- Get to know the areas where you plan to use your scooter. Look for hazards and learn how to avoid them.
- Do not use the scooter other than for its original purpose. Avoid any use, such as weight training, sports, athletics, hauling, moving or towing anything, that may lead to safety hazards and undue stress on the scooter.
- Your scooter is designed for one passenger only. Do not carry passengers on your scooter.
- We strongly recommend that you do not smoke cigarettes while seated on your scooter. You must adhere to the following safety guidelines if you decide to smoke cigarettes while seated in your scooter: Do not leave lit cigarettes unattended. Keep ashtrays at a safe distance from the seat cushions. Always make sure cigarettes are completely extinguished before disposal.
- Do not modify your scooter in any way by yourself. For any accessories, please contact the company you purchased your scooter from for installation by an authorized service technician.
- The addition of accessories to your scooter may change certain specifications such as overall weight, size, and /or the center of gravity of your scooter. Please note how some of the changes may damage any objects around you.
- Do not change your seating configuration. Please contact the company you purchased your scooter from for any adjustments.
- Do not use any replacement on your scooter, such as a different seating system. Only use the seating system that has been tested for safety and provided by the manufacturer.

GENERAL SAFETY INFORMATION

- Exercise extreme caution when using oxygen in close proximity to electrical circuits and combustible materials. Contact your oxygen provider for information on using oxygen safely.
- Do not change the settings on your controller. Please contact the company you purchased your scooter from if you notice any change in your ability to control the scooter.
- Do not use your scooter in "freewheel" mode without an attendant present.
- Do not place the scooter in "freewheel" mode while the unit is powered up. Always power off the scooter and remove the key from the key switch before engaging or disengaging "freewheel" mode.
- To prevent the scooter from rolling uncontrollably on its own, never place the scooter in "freewheel" mode on any incline or decline.
- If you anticipate being seated in a stationary position for an extended period of time, turn off the power to the scooter. This will prevent unexpected or unintended scooter movement.
- Avoid using any accessories that may interfere with the operation of the throttle control lever, which may result in unintended or uncontrolled movement of the scooter.
- Keep yourself, clothing, and all other objects away from the tires while driving. Do not allow any objects to drag behind the scooter when driving. Loose-fitting clothing or other objects can get caught in the tires and /or the running gear.
- Possible strangulation hazard! Be aware that clothing, lanyards, necklaces, other jewellery, purses, and other accessories worn or carried by you while you are seated on or operating the scooter may get caught around the armrests or throttle control lever.
- Do not connect any device to the scooter electrical system or use the scooter batteries to power

GENERAL SAFETY INFORMATION

- anything else other than your scooter.
- Always grasp the connector itself when disconnecting any wires. Do not pull on electrical harnesses directly
 - Keep all charger power cord connectors clean, dry and away from sources of dampness at all times to prevent damage to the electrical system and /or personal injury. Check any actuators for loose, worn, or damaged items and have any damaged wires replaced immediately.
 - Check electrical components frequently for signs of corrosion and have them replaced as necessary.
 - Always secure the scooter and its batteries when it is being transported. Batteries should be secured in an upright position and protective caps should be secured on the battery terminals. Do not transport the scooter and /or batteries with any flammable or combustible items.
 - Do not handle batteries without supervision by an authorized service technician. Battery posts, terminals, and related accessories contain lead and lead compounds and can be hazardous. Anyone lifting scooter batteries should use proper lifting techniques and avoid lifting beyond his/her capacity.
 - NEVER attempt to recharge the batteries by attaching cables directly to the battery terminals or clamps.
 - DO NOT attempt to recharge the batteries and operate the scooter at the same time.

GENERAL SAFETY INFORMATION

should be used in the scooter. Replacement batteries should be obtained directly from an authorized provider to ensure conformity, fit, and function.

- Always protect the batteries from freezing; for those living in cold climates, make sure you store the scooter properly. Never charge a frozen battery. Charging a frozen battery may result in damage to the battery and could be dangerous.
- Do not remove any fuse links (if fitted) from the battery harnesses. If the fuse links appear damaged, contact your authorized provider.
- Do not operate the scooter with depleted batteries; you could be stranded.
- Reduce your speed, do not make any sharp turns and maintain a stable center of gravity while turning /cornering. To prevent tipping, avoid shifting your weight in the opposite direction of a turn.
- While driving up inclines or low curbs, drive your scooter straight on with the wheels perpendicular to the incline and/or low curb; both front wheels should contact the incline/low curb at the same time. To reduce the possibility of a fall, do not drive at an angle; do not get one wheel or side of the scooter on the incline/low curb first. Always exercise extreme caution when negotiating an incline.
- Do not travel up or down potentially hazardous surfaces and/or inclines, including but not limited to areas covered with snow, ice, cut grass, or wet leaves.
- When climbing an incline, try to keep the scooter moving. If stopping is necessary, start up again slowly and then accelerate with caution.
- When descending an incline, use the slowest speed possible. If the descent is faster than you desire, release the throttle control lever to stop the scooter. Then press the throttle control lever slightly to

GENERAL SAFETY INFORMATION

control the speed of your descent.

- The maximum recommended incline angles (see specifications) are tested in a controlled environment. Your scooter's ability to climb up inclines is affected by your weight, speed and the angle you approach the incline among other factors.
- Only drive backwards on a flat surface. When driving backwards, operate your scooter at a lower and even speed. Stop often and check to make sure your path is clear of obstacles. To prevent tipping, do not travel down an incline or ramp backwards.
- To avoid overloading the scooters and potential tipping, never carry anything or fill the basket with contents weighing more than 15lbs (6.8kg).
- Avoid any change of position or movement that may change your center of gravity while sitting on the scooter. This may cause your scooter to tip.
- A drop-off (as small as 2 inches) at the bottom of a slope can stop a front wheel and cause the scooter to tip forward.
- Never reach or lean if you must shift your weight sideways or rise up off the seat.
- Never reach or lean if you must move forward in your seat to do so. Always keep your lower back in contact with the backrest.
- Never try to pick up an object from the floor by reaching down between your knees.
- Never reach or lean over the top of the seat back. This may damage the backrest and cause you to fall.
- Do not use the armrests for any weight bearing purposes. Such use may cause the scooter to tip, which may result in a fall from the scooter and personal injury.
- Do not put all of your weight on one side of the scooter deck. Such use may cause the scooter to tip.
- Even though your scooter may be capable of

GENERAL SAFETY INFORMATION

handling greater obstacles, we recommend that you do not attempt to negotiate a curb that has a height greater than 2" (5cm). Doing so could cause instability in your scooter. Riding over curbs or obstacles can cause tipping and serious bodily harm. If you have any doubt that you can safely cross any curb or obstacle, **ALWAYS ASK FOR HELP**. Be aware of your riding skills and personal limitations. You may need to remove or cover threshold strips between rooms and install a ramp at entry or exit doors.

- Do not try to climb an obstacle when on an incline.
- Do not drive over an obstacle with just one wheel.
- Do not drive on uneven terrain and/or soft surfaces.
- Do not drive near tall grass that can entangle the running gear.
- Avoid driving on loosely packed gravel and/or sandy surfaces.
- Do not use your scooter on or near railroad tracks or crossings.
- Do not ride your scooter along the edges of streams, lakes, or the ocean. Never use your scooter to cross waterways.
- If you feel unsure about a driving surface, avoid that surface.
- Do not expose your scooter to open flames.
- Keep your scooter in a dry and clean condition. Never take your scooter into a shower, tub, pool, or sauna. Rain, snow, salt, mist/spray conditions, and icy/slippery surfaces can damage the scooter components or cause the scooter frame to prematurely rust.
- Avoid prolonged exposure to heat or cold; it may affect the temperature of upholstered and non-upholstered components on the scooter. Exercise caution when using your scooter in extremely hot or

GENERAL SAFETY INFORMATION

cold conditions.

- Do not tow your scooter. Towing may exceed the maximum speed threshold, resulting in damage to critical components of the scooter.
- Use extreme caution when it is necessary to move an unoccupied scooter up or down stairs. Remove the seat, batteries, and any accessories before attempting the transfer. Use proper lifting techniques and use only solid, non-removable frame components to lift the scooter with multiple physically capable attendants. Do not lift or move your scooter or seating system by grasping or holding onto any of its removable parts, including the armrest(s), seat cushions, seatback, or shrouds.
- When your scooter is used with any type of lift/elevation devices, always turn off the power of the scooter; make sure the scooter is not in "freewheel" mode and do NOT sit on your scooter. Failure to follow this may result in unintended movement and personal injury or product damage.
- Never use your scooter to negotiate stairs or escalators.
- Never sit on the scooter while it is in a moving vehicle.
- It is dangerous to transfer to and from your scooter on your own. It requires good balance and agility. Be aware that there is a point during every transfer when the seat is not below you.
- To make a safe transfer: Always turn off the power before you transfer to or from your scooter. If you fail to do so you may touch the throttle control lever and cause your scooter to move when you do not expect it. Make sure motor locks are engaged; this keeps the scooter from moving when you transfer. Work with your health care professional to learn how to position your body and how to support yourself

GENERAL SAFETY INFORMATION

during a transfer. Have someone help you until you are sure you do a safe transfer on your own. Move your scooter as close as you can to the seat you are transferring to. Transfer as far back onto the seat surface as you can. This will reduce the risk that you will miss the seat or fall.

- Never transport the scooter in the front seat of a vehicle. It may shift and interfere with the driver.
- Always secure the scooter so that it cannot roll or shift.
- Should the fittings on your seating system become loose, contact the company you purchased your scooter from
- Replace worn or damaged upholstery immediately to reduce the risk of fire hazard.
- Be aware that washing of upholstered items may reduce the fabric's resistance to flammability.

GETTING TO KNOW YOUR SCOOTER

4. GETTING TO KNOW YOUR SCOOTER

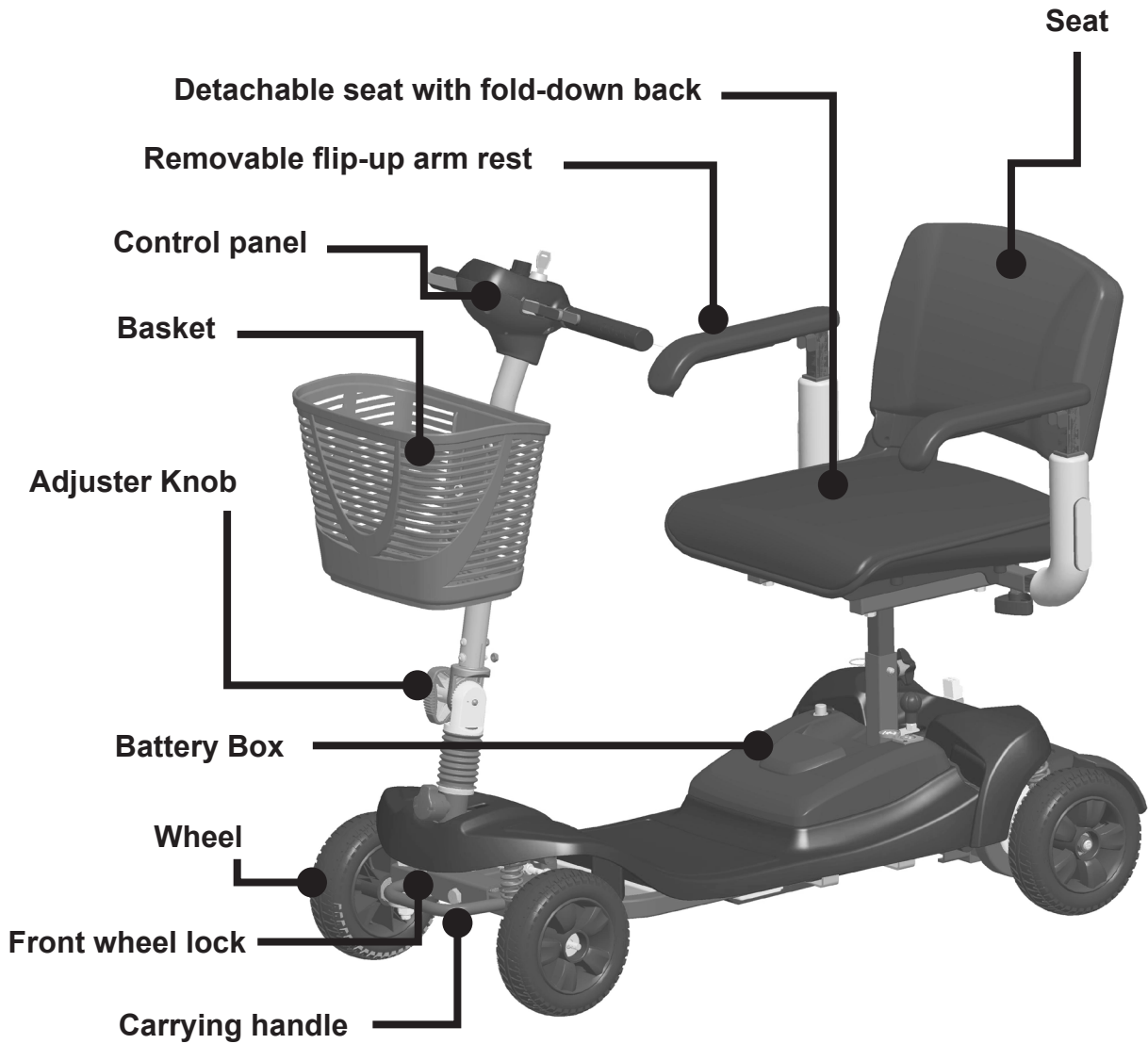

GETTING TO KNOW YOUR SCOOTER

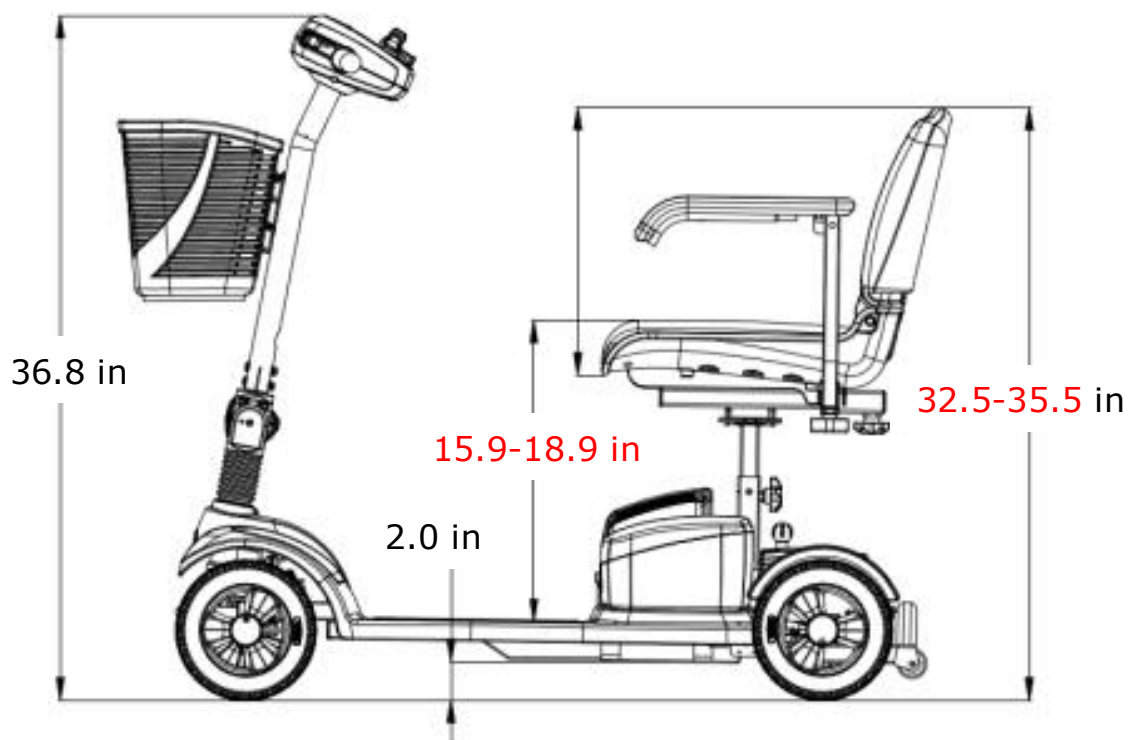
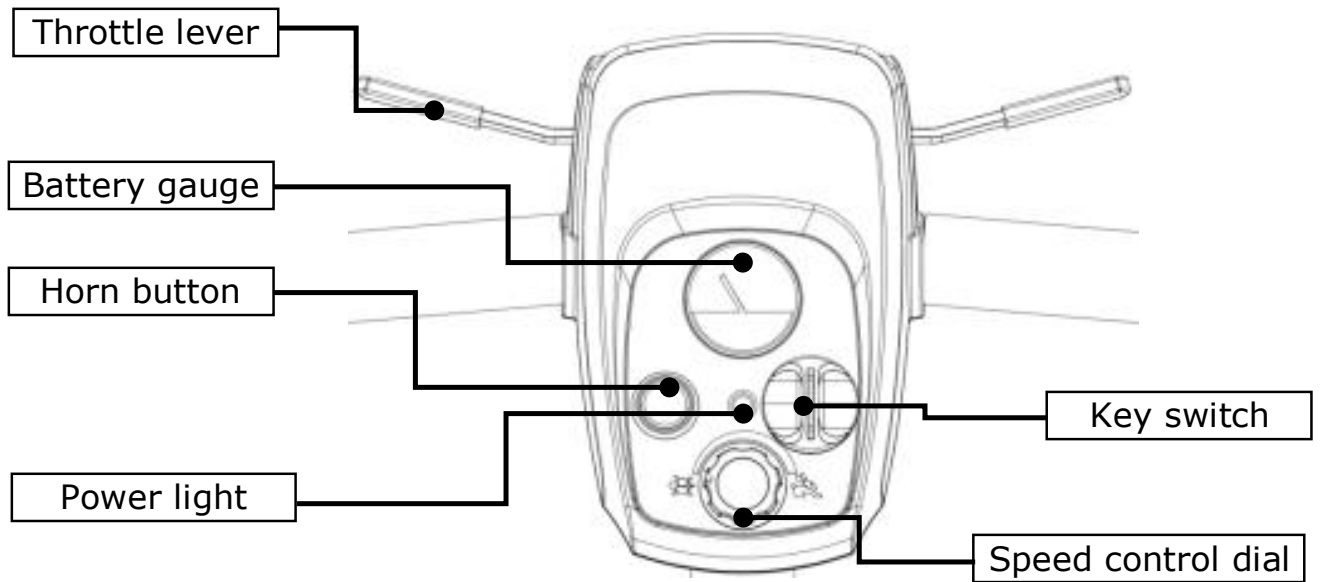

PRODUCT SPECIFICATIONS

5. PRODUCT SPECIFICATIONS

MODEL	Alumina	Alumina ^{Pro}
LENGTH	90cm / 35"	90cm / 35"
WIDTH	50cm / 20"	50cm / 20"
HEIGHT	50cm / 20"	105cm / 41"
FOLDED LENGTH	N/A	N/A
FOLDED WIDTH	N/A	N/A
FOLDED HEIGHT	N/A	N/A
SEAT WIDTH	45cm / 18"	45cm / 18"
SEAT DEPTH	39cm / 15.5"	39cm / 15.5"
FRONT WHEEL	Solid 19cm / 7.5"	Solid 19cm / 7.5"
REAR WHEEL	Solid 19cm / 7.5"	Solid 19cm / 7.5"
TOTAL WEIGHT	73lbs / 33kg	75lbs / 34kg
HEAVIEST PART	22lbs / 9.98kg	22lbs / 9.98kg
BATTERY WEIGHT	9lbs / 4kg	11lbs / 5kg
MAX USER WEIGHT	18stone / 115kg	18stone / 115kg
RANGE	15miles / 24km	30miles / 48km
SPEED	4mph / 6kph	4mph / 6kph
BATTERY	24v 19.35ah Lithium	24v 37.2ah Lithium
MOTOR	24v 200w	24v 200w
GROUND CLEARANCE	5cm / 2"	5cm / 2"
MAX GRADIENT	6°	6°
TURNING RADIUS	125cm / 49"	125cm / 49"
BOX DEPTH	114cm / 45"	114cm / 45"
BOX WIDTH	53cm / 21"	53cm / 21"
BOX HEIGHT	53cm / 21"	53cm / 21"

***1. Range can be affected by; User weight, driving surfaces, inclines, stop & starting, turning and battery condition!**

6. PUSHING AND TRANSPORTING THE SCOOTER

1. Please carefully read the safety information in section 3 related to transportation first.

2. Pushing the scooter:

In order to push the scooter, you must place the scooter in **"freewheel" mode**, which disengages the drive motor. The release lever is located at the bottom right-hand side of the scooter under the seat.



WARNING!

When the lever is pushed into the freewheel mode:

- The scooter must be on a flat surface and stationary.
- Do not sit on the scooter.

To push the scooter:



=Freewheel Mode: (Motor is disengaged.)

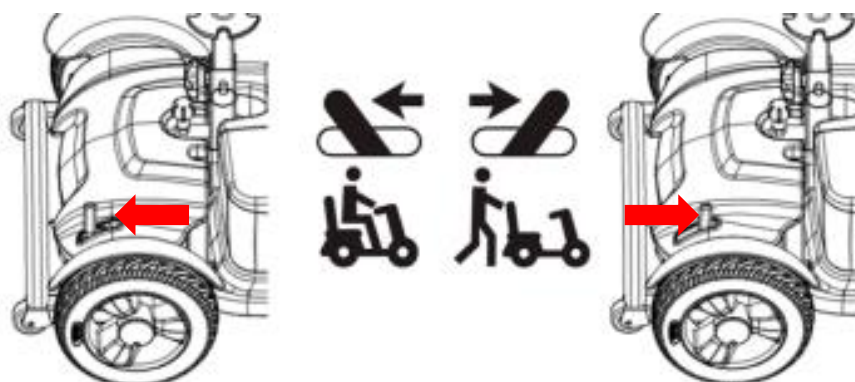

1. Power off the scooter and remove the key.
2. Push the lever forward as far as the stop for freewheel mode (see diagram).
3. Push the scooter to your desired location.
4. Pull the lever back as far as the stop, to lock into drive mode (see diagram).

TRANSPORTING YOUR SCOOTER



=Driving Mode:(Motor is engaged.)



1. Always switch the scooter off to push it.
2. Do not push the scooter too fast. If a pre-set speed is exceeded while you are pushing the scooter, the drive motor will switch on automatically and brake the scooter.



After **any** adjustments, repair or service and **before** use, make sure all hardware is tightened securely - otherwise injury or damage may result.

6.1 Parts

You can disassemble the scooter into five pieces: the seat, the front section, the basket, the battery pack, and the rear section.

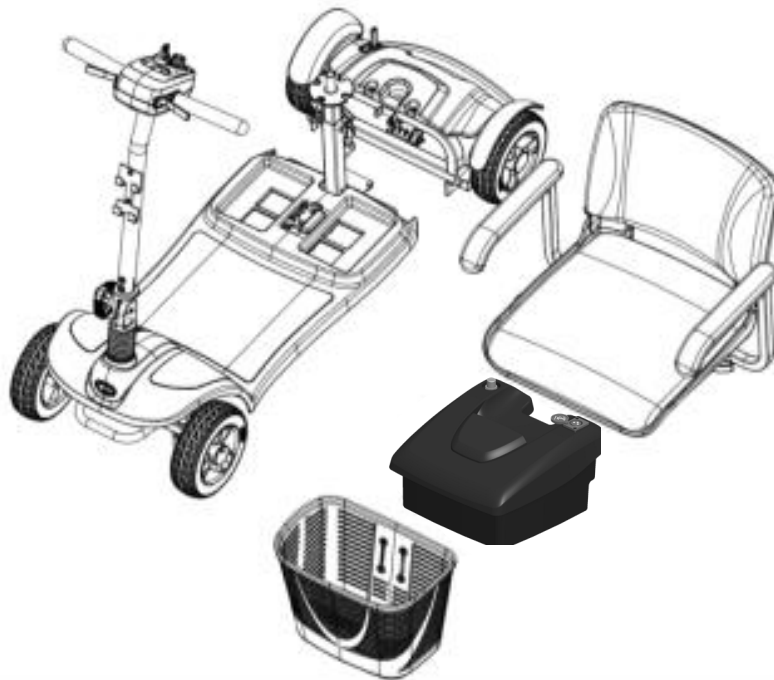

1. Place the scooter in an area where you have sufficient

TRANSPORTING YOUR SCOOTER

clearance to move the parts around. You may need assistance to lift some of the scooter components.

2. See "Specifications" for individual component weights.
3. No tools are required to disassemble or assemble your scooter. Always disassemble or assemble your scooter on a level, dry surface with sufficient space for you to work and move around your scooter. Keep in mind that the disassembled sections of the scooter take up more floor space than the assembled scooter.



Lifting a weight beyond your physical capability may result in personal injury.

Ask for assistance when necessary while disassembling or assembling your scooter.

TRANSPORTING YOUR SCOOTER

6.2 To Disassemble:

1. Turn key switch to "OFF".
2. Place the free wheel mode lever in the drive position.
3. Pick up the battery pack and remove it from the scooter. (See the Fig.)

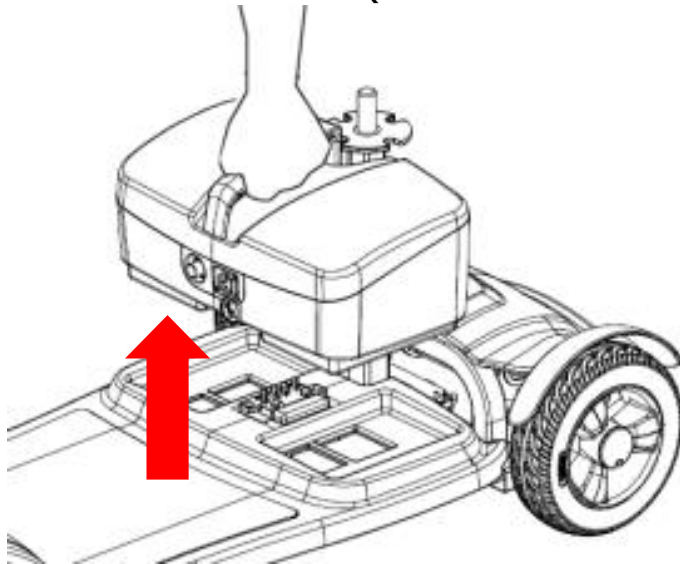

4. Pull the release knob upward and lift and the front section apart from the rear section. (See the Fig.)

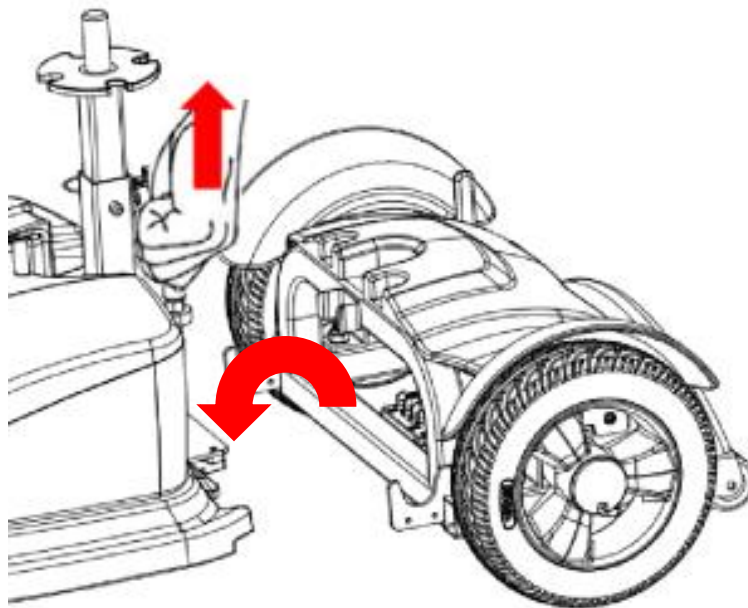

TRANSPORTING YOUR SCOOTER

6.3 ASSEMBLY



Note: Raise the tiller before reassembling the scooter.

1. Place the freewheel mode lever in the drive position.
2. Set the rear section in the up position and pick up the front section to the connecting bracket of rear section. (See Fig)

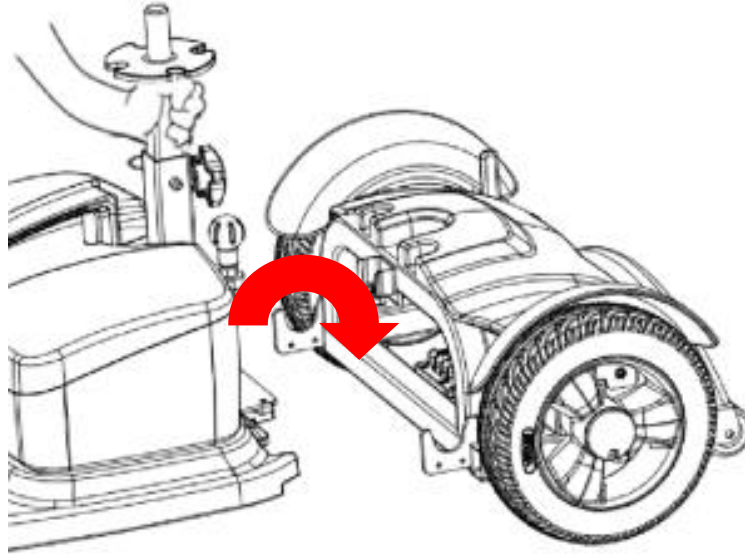

Make sure the release knob is re-engaged fully to the rear section and fully locked into place.

3. Make sure that the front and rear sections are level.
4. Fit the battery pack on the scooter. (See the Fig.)

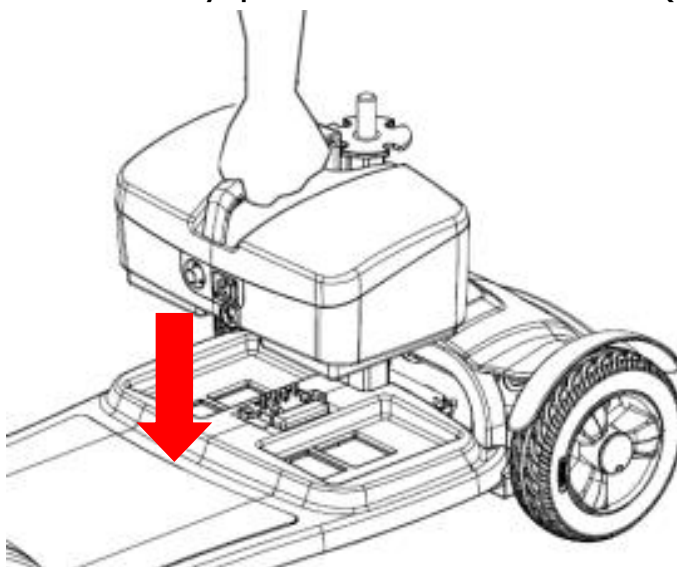

TRANSPORTING YOUR SCOOTER

5. Fit the seat on the seat post, insert the seat post and screw the knob .
6. Turn key switch to "ON", make sure battery gauge has sufficient power.



Make sure you connect all the pieces together properly.



Turn off all power to your scooter and remove key from key switch to avoid accidents prior to disassembly.



Ensure the front and rear sections are in the right position before driving.

ADJUSTING THE SCOOTER

7. ADJUSTING THE SCOOTER

The following describes how to set up and adjust your Scooter in order to have a comfortable and safe drive.

7.1 SWIVELING THE SEAT TO GET ON AND OFF

1. Lift the seat lever and rotate the seat to the side (left or right) to get on.
2. Sit on the seat and turn the seat back to the direction of travel. Lock the seat in place by releasing the seat lever.

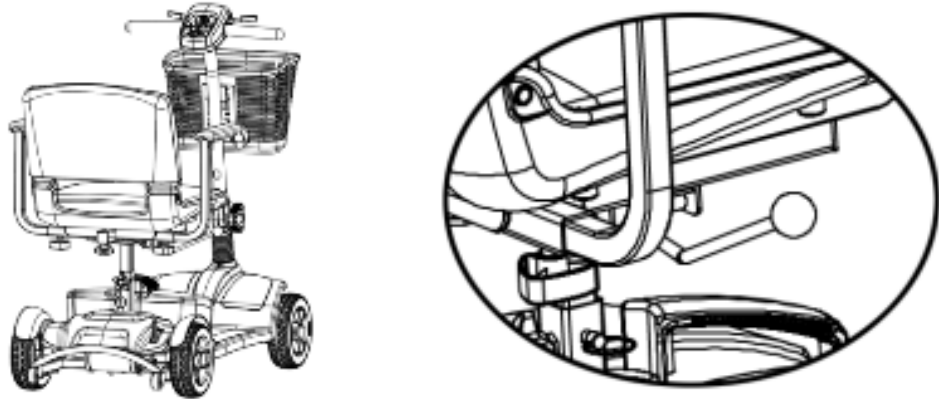

 *Ensure that the seat is properly engaged after adjustment by seeing that the seat doesn't move when you try rotating it to either side*

7.2 ADJUSTING THE TILLER ANGLE

Always adjust the tiller so that you can reach the dashboard and control your scooter easily at any time. The Tiller can be adjusted by the following steps.

1. Loosen the knob by turning counter-clockwise. Adjust the tiller angle.

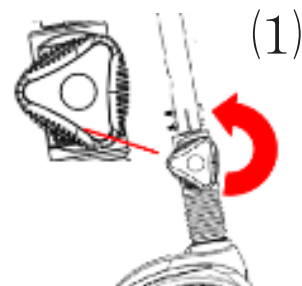

ADJUSTING THE SCOOTER

2. Tighten the knob by turning clockwise, and make sure the tiller is securely fixed.

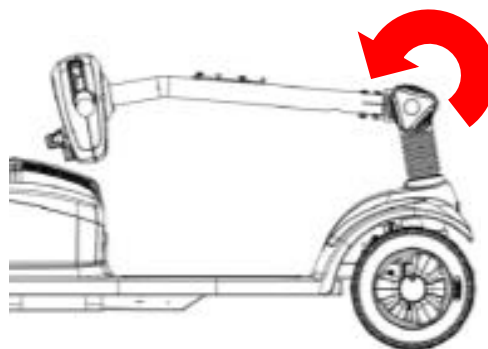

Accident hazard due to non-engaged tiller:

Ensure that the tiller is properly locked after adjustment by seeing that it doesn't move when you try pushing it slightly forwards and backwards

7.3 TURNING THE SEAT

Pull swivel seat lever to rotate the seat.

The seat has 4 height adjustments.

After adjusting the height to the desired seat position, secure the fixed nut.

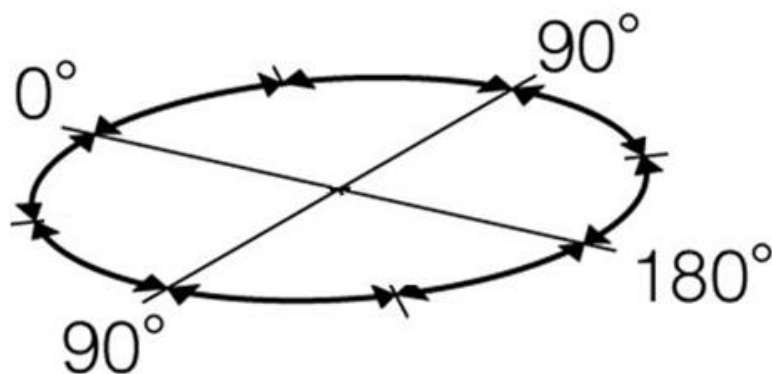

ADJUSTING THE SCOOTER

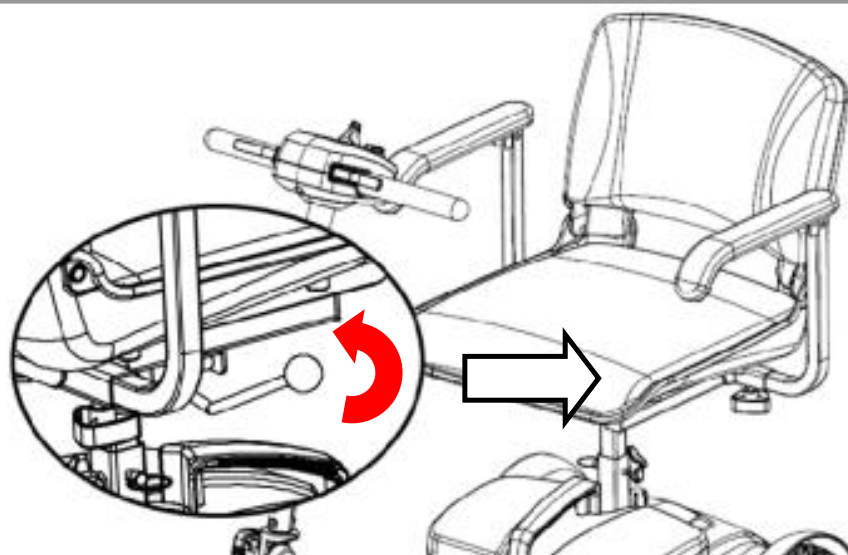

Accident hazard due to incorrect seat position:

Always turn the seat to face forward and lock it before driving.

If the seat has been turned, the possibility of tipping is increased.

Before turning the seat, always ensure that the scooter is on an even and solid surface.

8. OPERATING THE SCOOTER

Always carry out the safety information described in the “General Safety Information” section:

Before starting to drive, adjust the seat and tiller to a comfortable position.

 **WARNING!** *Every scooter is different. Take the time to learn the feel of your scooter before you begin riding.*

 **WARNING!** *BE AWARE* that becoming a capable and safe scooter operator will take time and practice.

 **WARNING!** *Anti-tippers substantially reduce your risk of tipping over backwards, which can cause serious injury.*

Please observe the following tips for a safe journey:

1. Always match your speed to the driving situation in which you find yourself.
2. Always reduce your speed when you are driving through:
 - Unclear areas
 - narrow gaps
 - Tight curves
 - inclines
 - Ramps
3. Take a trial run with the scooter in an area with no pedestrians, or in a closed-off area.
4. Always steer the scooter with both hands on the handlebars.
5. Always keep your feet within the foot area while driving the scooter.
6. Check before you power on the scooter:

OPERATING THE SCOOTER

Ensure your scooter is in drive mode (not in "freewheel" mode)	Check the "freewheel" mode lever is in the pushed down position
Seat is locked into the desirable position	Move the seat forwards and backwards to ensure it is stationary.
Are the batteries charged?	Check the dashboard to verify the charge status of the batteries
Are the brakes working?	Check by driving slowly and stopping again
Are the tires and wheels free from any damaged?	Visually check the tires and wheels

8.1 POWERING ON/OFF

The switch is located near the right side of the dashboard.

Insert the key into the switch and turn it to the right to power on the scooter.

Turn it to the left to power off the scooter.

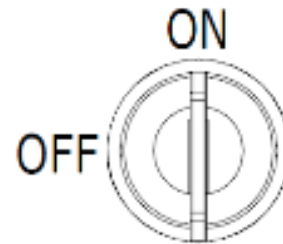

8.2 ADJUSTING THE SPEED



Use the speed adjustment mechanisms to adjust the speed to suit your driving conditions.

Always use lower speed if you are uncertain about the driving conditions.

There is one mechanism to control the speed of your scooter.

1. Speed Control Dial:
 - a. It is located in the center of the dashboard.
 - b. It is designed to allow you to adjust the speed from low to maximum speed (Maximum = Rabbit).

OPERATING THE SCOOTER

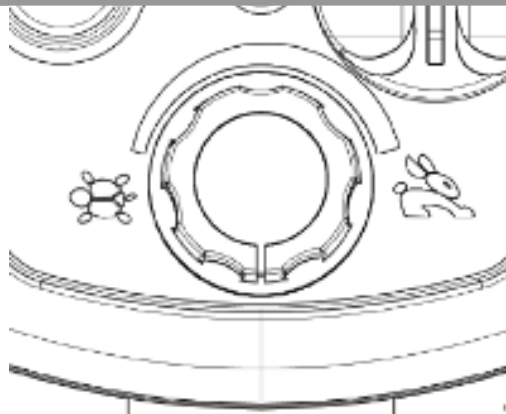

Anticipated Speed levels:

- c. The speed levels are tested under controlled environments and your driving speed may vary depending on the driving conditions and loads.

8.3 DRIVING FORWARDS AND BACKWARDS

Hold the tiller handles firmly with both hands.

Use your right index and middle fingers to pull the right side of the lever to move forward.

F= driving forwards

Release the lever and allow the scooter to come to a complete stop.

Use your left index and middle fingers to pull the left side of the lever to move backwards.

R= driving backwards

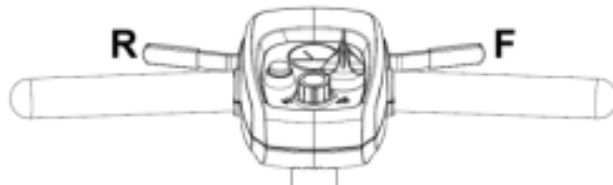

Do not pull both sides of the throttle control lever simultaneously.

OPERATING THE SCOOTER

8.4 OVERLOAD PROTECTION

The overload protection switches the power off when the motor becomes overloaded while trying to climb over too high an obstacle, such as a curb or trying to climb too steep of an incline.

If the motor is overloaded, the following happens:

- The scooter becomes noticeably slower and then stops
- The scooter system shuts down the scooter

To rectify this:

Switch the scooter off and allow it to cool down for a few minutes.



Push to reset the overload switch located on the battery box (see diagram).

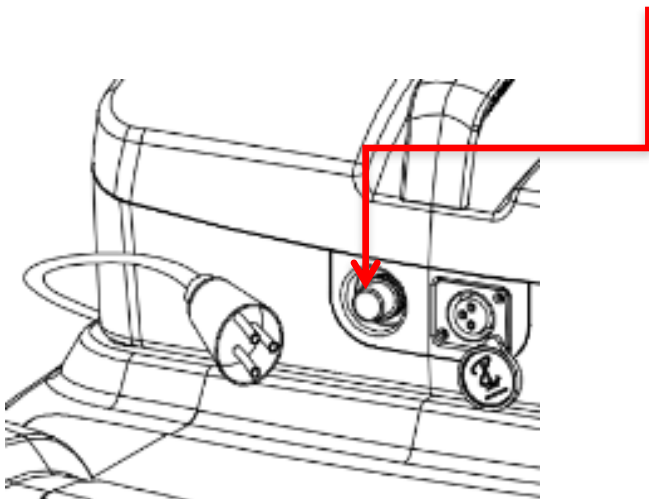

Switch the scooter on and reverse away from the obstacle (such as a curb) and then avoid the obstacle.

8.5 SWITCHING ON THE HORN

Press the **horn button**.

It will sound for as long as you hold the button down.

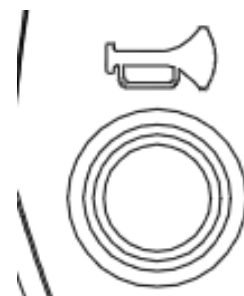

OPERATING THE SCOOTER

8.6 DRIVING ON AN INCLINE

TIPPING HAZZARD!



When driving on an incline reduce your speed. Lean your body forward to increase your stability and to avoid tipping backwards. Always avoid leaning backwards while driving up an incline. Observe the safe climbing angle in the product specifications and always access the driving surface, as this can be a factor for safe incline driving (For example ice and leaves can cause loss of wheel traction and prevent safe incline driving).

Avoid stopping and re-starting on an incline if possible. If you do need to stop, re-start driving very slowly and then slowly increase your speed smoothly.

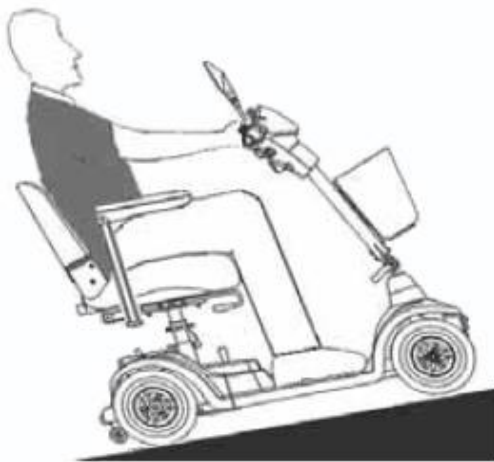

Avoid leaning backward (not recommended).











Lean forwards to increase stability (recommended).

NOTE: Maximum incline angle = 6 degrees !

BATTERY AND CHARGING THE BATTERY

9. BATTERY AND CHARGING THE BATTERY

	Corrosive chemicals contained in battery.
	Explosive conditions exist!
	Warning hands pinching!
	Do not use batteries with different amp-hour (Ah) capacities.
	Keep tools and other metal objects away from battery terminals. Contact with tools can cause electrical shock.
	Flammable material contained in battery. Do not expose to heat sources such as open flame or sparks. Do not transport batteries with flammable or combustible items.
	Disposal and recycling - Contact your approved service provider.

 *New batteries **MUST** be fully charged (approximately 24 hours) prior to initial use of the equipment.*

Always charge new batteries before initial use or battery life will be reduced.

As a general rule, you should recharge your batteries as frequently as possible to assure the longest possible life and to minimize required charging time. Plan to recharge them when you do not anticipate using the equipment.

BATTERY AND CHARGING THE BATTERY

The range per battery charge, using recommended batteries, should be approximately 8 to 12 hours of typical operation. Extensive use on inclines may substantially reduce per charge mileage.

9.1 BATTERY STATUS DISPLAY

When the key is switched "ON", the battery gauge will display the battery power capacity by indicating red, yellow and green areas respectively.

Green area indicates a full charge from the battery. Red area indicates low power.

The remaining power indicated by the battery

gauge will be varied by the actual driving time and how you drive. Repeated starting, stopping or climbing will consume the power more quickly.

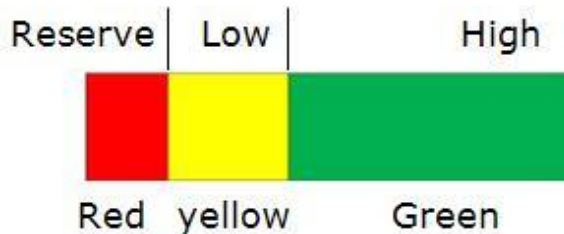

If the vehicle is under a heavier load, such as fast acceleration or driving up inclines, the battery status display may move towards the red zone.

This may not indicate the actual status of the batteries.

After a journey, the battery status display may move towards the green zone after the scooter has been turned off for a long period of time.

If a battery status display is in the red zone at the end of a journey, the battery must be charged immediately. Otherwise, it can lead to battery damage.

BATTERY AND CHARGING THE BATTERY

9.2 CHARGING THE BATTERIES

It is imperative that you observe the sequence for connecting and disconnecting the battery charger.

Be sure to follow the procedures shown below accordingly.

1. Turn the scooter key switch to "OFF".
2. Connect the charger cord to the power outlet.
3. Open the charging socket cap then connect the charger plug to the charging socket.
4. The charger's LED light will be red at the beginning of a charge. The charging duration is at least 8 - 12 hours (but this will vary), based on the status of the battery and temperature.
5. The red LED will turn to green when the charging is complete.
6. Disconnect the cord and remove the round plug from the charge socket.



CAUTION

Do not share the outlet with any other device.



CAUTION

To avoid the risk of electric shock, this equipment must only be connected to a grounded supply main.



CAUTION

Never use an extension cord to plug in your battery charger.

BATTERY AND CHARGING THE BATTERY

Step 1. Position the scooter near an electric outlet.

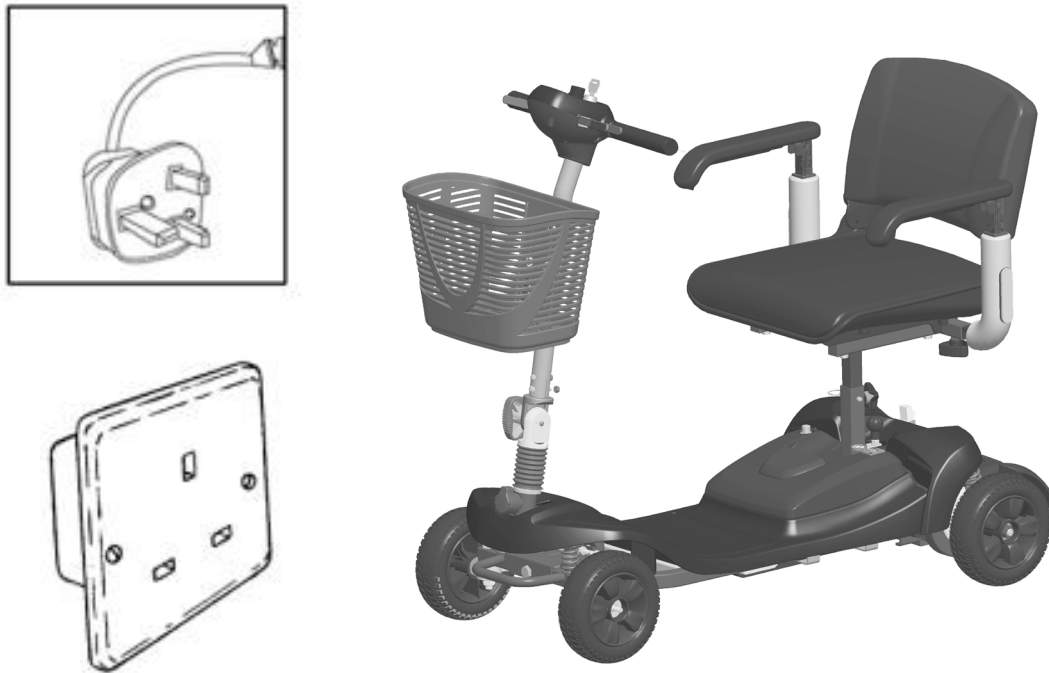

Step 2. Switch the scooter off and remove the key.

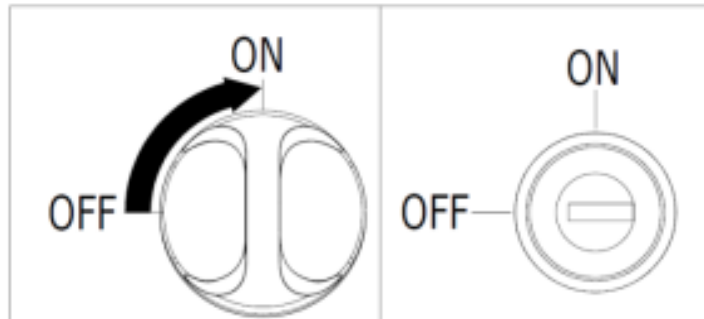

Step 3. Ensure the lever for "freewheel" mode is pushed down to the "drive" position.

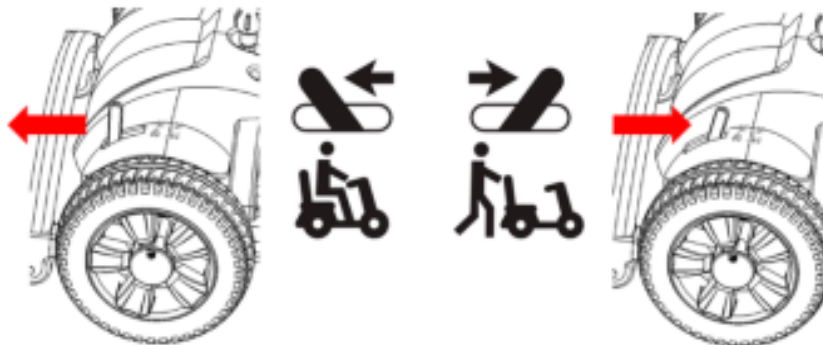

BATTERY AND CHARGING THE BATTERY

Step 4. Connect the battery charger plug into the scooter charging socket located in the center of the battery box.

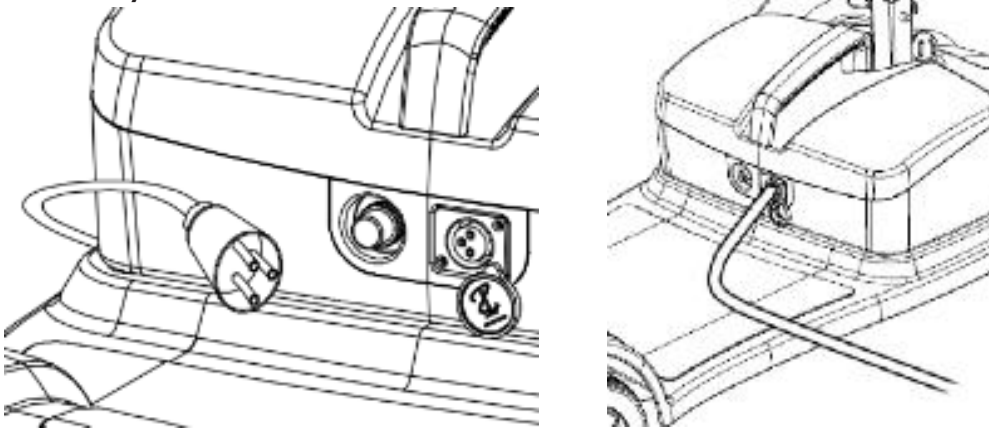

Step 5. Connect the battery charger power plug into an electrical outlet (AC100-240V, 50 to 60 Hz) and charge the battery. (Note: There is no switch on the battery charger).

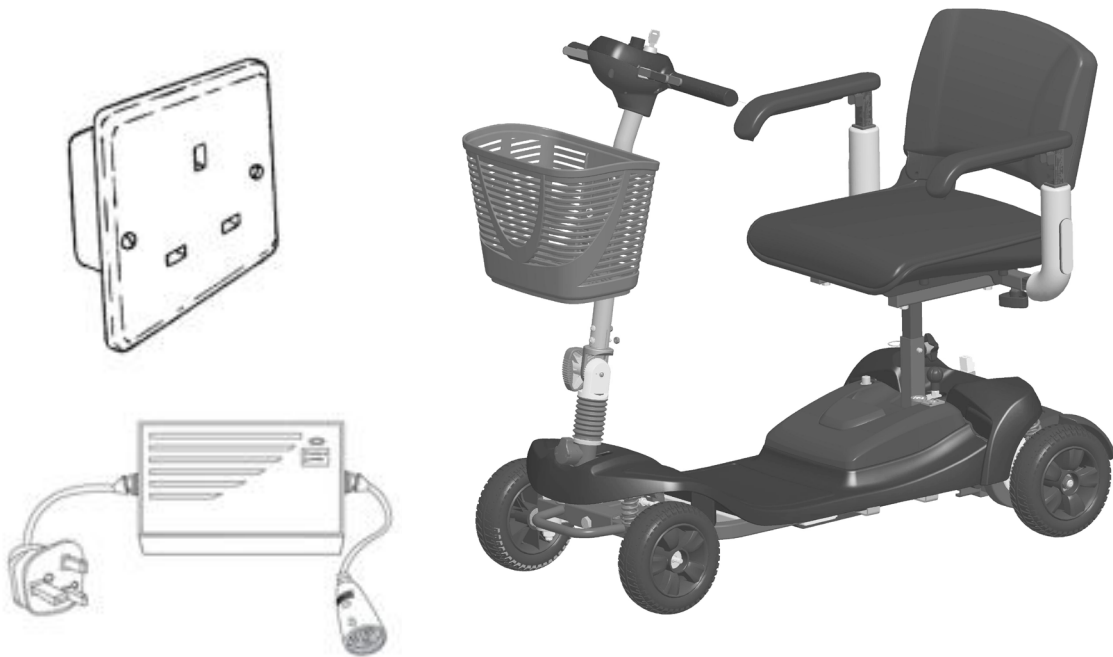

BATTERY AND CHARGING THE BATTERY

LED information at battery charger during

Charging:

LED-> Color-> Meaning

1 --- Red --- charging in progress

2 --- Green --- charging is complete

9.3 AFTER CHARGING

(1) Remove the battery charger jack plug from the battery box socket.

(2) Remove the battery charger plug from the electric outlet.

9.4 ERROR CODE

Flash code	Possible	Solution
1	The battery needs charging or there is a bad connection to the battery.	Check the connections to the battery. If the connections are good, try charging the battery.
2	There is a bad connection to the motor.	Check all connections between the motor and the controller.
3	The motor has a short circuit to a battery connection.	Contact your service agent.
4	Not used.	
5	Not used.	

BATTERY AND CHARGING THE BATTERY

6	The controller is being inhibited from driving.	Check the battery charger connector. Remove the battery charger from the scooter.
7	A speed control lever fault is indicated.	Make sure that the speed control lever is in the rest position before switching on the scooter.
8	A controller fault is indicated.	Make sure that all connections are secure.
9	The parking brakes have a bad connection.	Check the parking brake and motor connections. Make sure the controller connections are secure.
10	Excessive voltage has been applied to the controller.	Check the battery connections. This is usually caused by a poor battery connection.

If your meter diagnostic light shows any of the above signals, please contact your approved service provider!

10.EMI

This portion of the content will provide the user with basic information about the problems with EMI (electromagnetic interference), protective measures can be used to either lessen the possibility of exposure or to minimize the degree of exposure; this section also shows some conditions that unexpected or erratic movements may cause.



CAUTION *It is very important that you read this information regarding the possible effects of electromagnetic interference on your electric Scooter.*

ELECTROMAGNETIC INTERFERENCE (EMI) FROM RADIO WAVE SOURCES

Powered scooters may be susceptible to electromagnetic interference (EMI), which is interfering electromagnetic energy (EM) emitted from sources such as radio stations, TV stations, amateur radio (HAM) transmitters, two-way radios, and cellular phones. The interference (from radio wave sources) can cause the powered scooter to release its brakes, move by itself, or move in unintended directions. It can also permanently damage the powered scooter's control system. The intensity of the interfering EM energy can be measured in volts per meter (V/m). Each powered scooter can resist EMI up to a certain intensity level". The higher the immunity level the greater the protection. At this time, current technology is capable of achieving at least a 20 V/m immunity level, which would provide useful protection from the more common sources of radiated EMI. This powered scooter model as shipped, with no further modification, has an immunity level of 20 V/m without any accessories.

There are a number of sources of relatively intense electromagnetic fields in the everyday environment. Some of these sources are obvious and easy to avoid. Others are not apparent and exposure is unavoidable. However, we believe that by following the warning listed below, your risk to EMI will be minimized.

The sources of radiated EMI can be broadly classified into three types:

1. Hand-held portable transceivers (transmitter-receivers with the antenna mounted directly on the transmitting unit). Examples include: citizens band (CB) or hand held radios, (security, fire, and police transceivers), cellular telephones and other personal communication devices.

NOTE: some cellular telephones transmit a signal while they are ON, even though they are not being used.

2. Medium-range mobile transceivers, such as those used in police cars, fire trucks, ambulances and taxis usually have the antenna mounted on the outside of the scooter.
3. Long-range transmitters and transceivers, such as commercial broadcast transmitters (radio and TV broadcast antenna towers) and amateur (HAM) radios.

NOTE: Other types of hand-held devices, such as cordless phones, laptop computers, AM/FM radios, TV sets, CD player, and cassette players, and small appliances, such as electric shavers and hair dryers, are not likely to cause EMI problems to your powered scooter.

POWERED SCOOTER ELECTROMAGNETIC INTERFERENCE (EMI)

EM energy rapidly becomes more intense as one moves closer to a transmitting antenna (source). The **EM fields** from hand-held radio wave sources (transceivers) are of special concern. It is possible to unintentionally bring high levels of **EM energy** very close to the powered scooter's control system while using these devices; this can affect your scooters movement and braking. Therefore, the warnings listed below are recommended to prevent possible interference with the control system of a powered scooter.

 Electromagnetic interference (EMI) from sources such as radio and TV stations, amateur radio (HAM) transmitters, two-way radios, and cellular phones can affect motorized scooters. Following the warnings listed below should reduce the chance of unintended brake release or powered scooter movement which could result in serious injuries.

1. Do not operate hand-held transceivers-receivers, such as citizens band (CB) radios, or turn ON personal communication devices, such as cellular phones, while the powered scooter is turned ON.
2. Be aware of nearby transmitters, such as radio or TV stations, and try to avoid getting close to them.
3. If unintended movement or brake release occurs, turn the powered scooter OFF as soon as it is safe.
4. Be aware that adding accessories or components, or modifying the powered scooter, may make it more susceptible to EMI.
5. Report all incidents of unintended movement or brake release to the scooter manufacturer, and note whether there were sources of EMI nearby.

IMPORTANT INFORMATION

20 Volts per meter (V/m) is generally a useful immunity level against EMI (the higher the level, the greater the protection).

This product has an immunity level of 20 V/m without any accessories connected to it.

UK AUTHORISED DEALER

Motion Healthcare Ltd.
Hubert Road
Brentwood
Essex
CM14 4JE

Tel: 0844 257 8150
www.motionhealthcare.co.uk

Motion
healthcare